

Hi-Temp IR[®]

Model 5209 High Temperature Infrared Heater

Product Data Sheet



High Temperature Infrared Heater

The Model 5209 Hi-TempIR[®] heater is designed to provide high-intensity infrared heat onto localized areas.

Typical applications for this heater include:

- Stress relieving
- Metal brazing processes
- Aerodynamic heating simulation
- Thermal stress testing

Fast-Response Quartz Lamps

Yield 90 percent output within three seconds – dissipates 90 percent energy within five seconds.

Non-Contact Electric Heat Source

Heat source does not contact product being heated.

Localized Heat

Energy generated by unit heats desired target area without heating surrounding areas.

Heat Flux Densities

As high as 400 watts/in.² (62 kW/cm²).

Controllable Energy Output

Can be adjusted to match process requirements.

Repeatable Results

Can be achieved for consistent process outputs.

Fast. Focused. Controlled.



Hi-TempIR-5209-D-01-A

Description

The Model 5209 directs high-density infrared energy onto localized areas. The basic heater includes the following major components:

Heater Module – The heater consists of a specular aluminum reflector that directs the infrared energy generated by six ceramic end-seal, ‘T-3 style’, quartz halogen lamps factory-installed in the heater. Heated lengths of 5-, 10-, and 16-inches (127-, 254-, and 406 mm) are offered for the Model 5209. Additional lamps can be ordered separately from the heater.

Water Cooling – Adequate cooling water is required during operation of the Model 5209. Twenty feet (6 m) of tubing and plumbing fittings are supplied with each heater for easy installation. Required cooling water flow rates are listed in Specifications.

Air Cooling – Compressed air cooling must also be supplied to the heater for proper operation. This cooling air removes excess heat from around the lamp end-seals. A 10-foot (3 m) length of flexible tubing and matching plumbing hardware is included with each heater. Required airflow rates and pressures are listed in Specifications.

Removable Electrical Cable – The Model 5209 heater is electrically wired from the T3 lamps to intermediate terminal blocks within the heater. Further wiring from each terminal block to a pinned connector on the top of the heater is also included. A 10-ft. (3m) removable electrical cable is supplied with each heater that is designed to mate with the heater’s pinned connector. This cable is designed for installation within an electrical junction box (optional item) or installed within an appropriately designed power source.

Heater Safety – An integrated thermostat is mounted to the backside of the aluminum reflector. The thermostat is wired to the pinned connector with corresponding wiring residing in the removable electrical cable. When wired into an appropriately designed power source, the normally closed thermostat will open upon reaching an overheat condition preventing electrical power from reaching the heater. The thermostat will close once the heater cools down to a safe operating temperature.

Optional Quartz Window – A quartz window can be ordered along with the Model 5209. When installed in the heater, the quartz window protects the aluminum reflector and lamps from contaminants released during the heating process resulting in maximum efficiency of the heater.

Optional Electrical Junction Box – An optional electrical junction box can be ordered with the Model 5209. The junction box accommodates all of the wiring present within the removable electrical cable and is designed to accept either a 240- or 480-volt (single- or three-phase) electrical supply source.

Optional Power Control System – The Model 5209 can be ordered with the ‘PC’ option. This configuration consists of the heater, removable electrical cable wired to a junction box and a Research Inc. Model 915 (single-phase) or Model 935 (three-phase) SCR-based power control system, also wired to the junction box. This power control system is designed to match the electrical supply needs of the heater. Please see the Model 915 or Model 935 ControllIR[®] product data sheet for further detail.

Features and Benefits

The design and functionality of the Model 5209 supplies a variety of features and related benefits:

Rapid Response – The quartz halogen lamps heat up and cool down instantly in response to power control signals. They reach 90 percent of full operating temperature within three seconds of a cold start. The radiant energy dissipates to ten percent five seconds after the power supply is disconnected.

Continuous Operation – The formed stainless steel and extruded aluminum construction of the Model 5209 combined with the liquid and air-cooling, allows the heater to withstand continuous high temperature operation.

Controllable Energy Output – The infrared energy emitted from the heater can be adjusted to match the heating requirements of a variety of applications.

The Model 5209 ordered with the 'PC' option is a complete heating and control solution designed with a number of features including heater on/off control switching, potentiometer local control, and mechanically interlocked doors with main power disconnect switch. Heater over-temperature indicators, a digital voltmeter and system cooling on/off control switches with indicator lamps are also included.

The complete system allows the end user to easily install both the heater and controller within the given application. The heater is supplied with a 10-foot (3 m) removable electrical cable and is terminated within Model 5209 Junction Box. A separate 30-foot (9.1 m) electrical cable connects the Junction Box to the power control system (either the Model 915 or Model 935 ControllR®). This 'plug and play' feature simplifies installation for the end user and allows the heating system to be put into use very quickly.

Dimensions – Model 5209

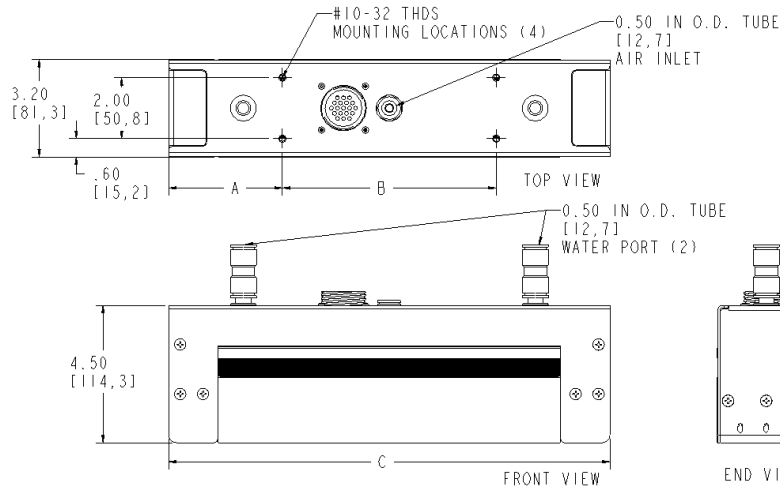

Model Number	Dimension, Inches (mm)		
	A	B	C
5209-05	1.8 (45.7)	5.5 (139.7)	9.10 (231.1)
5209-10	3.73 (94.7)	7.00 (177.8)	14.45 (367.0)
5209-16	3.73 (94.7)	12.63 (320.8)	20.08 (510.0)

Note: The height and width dimensions are identical on all three sizes of the Model 5209.

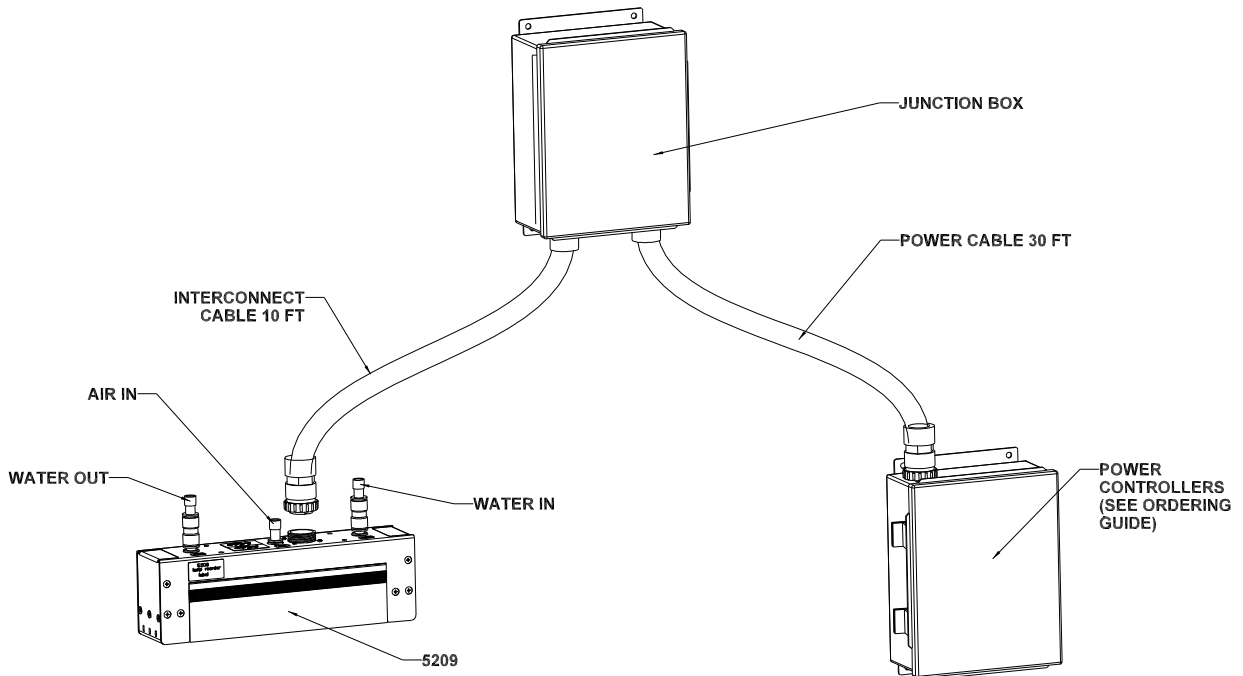

Specifications – Model 5209

Specification	5209-05	5209-10	5209-16
Weight, Pounds (kg)	7.5 (3.4)	10 (4.5)	12.8 (5.8)
Lamp Type	QIH240-1000RI2	QIH240-2000RI2	QIH240-3000RI2
Lighted Length, Inches (mm)	5 (127)	11 (280)	16 (406)
Rated Lamp Voltage	240	240	240
Total Power Dissipated at Rated Voltage, kW	6	12	18
Cooling Water Flow, GPM (l/min.)	1.0 (3.8)	1.5 (5.7)	2.0 (7.6)
Cooling Air Flow, SCFM (M ³ /min.)	4.0 (0.11) @ 3.0 PSI	4.0 (0.11) @ 1.0 PSI	4.0 (0.11) @ 1.0 PSI
With a Regenerative Blower CFM (M ³ /min) @6.2 PSI	20 (0.57)	20 (0.57)	20 (0.57)

Control options	5209-05	5209-10	5209-16
Single Phase voltage controllers			
SCR control Module Must be installed in safety Protected enclosure	Model 1022-240V-30A-POT SCR Module 240 Volt	Model 1022-240V-70A-POT SCR Module 240 Volt	Model 1022-240-80A-POT SCR Module 240 Volt
SCR Controller. Bench or Wall mount	Model 5620-3-2-00 SCR Power Controller 240 Volt	Model 5620-3-3-00 SCR Power Controller 240 Volt	
SCR power control System NEMA 12 cabinet, Voltage, air And water safety interlocks	Model 915 –A 240-40-00 SCR Control Cabinet 240 volt	Model 915-A-240-70-00 SCR Control Cabinet 240 Volt	*Model 915-A-480-40-00 SCR Control Cabinet 480 Volt
Three Phase voltage controllers			
SCR control Module Must be installed in safety Protected enclosure		Model 3629C-240-50A-POT SCR Module 240 Volt	Model 3629C-V-240V-80A SCR Module 240 Volt
SCR power control System NEMA 12 cabinet, Voltage, air And water safety interlocks		Model 935-A-240-50-00 SCR Control Cabinet 240 Volt	Model 935-A-240-80-00 SCR Control Cabinet 240 Volt

*Lamps will need to be wired in series / parallel for 480 volt operation

Accessories, Spare & Replacement Parts – Model 5209

Model	Description
106609-003	Quartz Window Kit, 5-inch (127 mm) lighted length heater
106609-001	Quartz Window Kit, 10-inch (254 mm) lighted length heater
106609-002	Quartz Window Kit, 16-inch (406 mm) lighted length heater
103390-002	Quartz, Halogen Infrared Lamp, Ceramic end-seal, 5-inch (127 mm) lighted length
103390-004	Quartz, Halogen Infrared Lamp, Ceramic end-seal, 10-inch (254 mm) lighted length
103390-006	Quartz, Halogen Infrared Lamp, Ceramic end-seal, 16-inch (406 mm) lighted length
106513-001	Electrical Junction Box, accepts Model 5209 Removable Electrical Cable
106514-001	10-ft. (3 m) Electrical Cable Assembly, Model 5209 Heater-to-Junction Box
106610-001	30-ft. (9.1 m) Electrical Cable Assembly, Model 5209 Junction Box-to-Power Control Box
106617-001	Cooling Air Regulation Kit
106618-001	Cooling Water Regulation Hardware Kit

Research, Inc. reserves the right, without notice, to alter or improve the designs or specifications of the products described herein. No warranty or guarantee of any kind is expressed or implied by information contained herein. Printed in U.S.A. © Research, Inc., May 2002.

Represented by: