

### Model 4555



**FAST. FOCUSED. CONTROLLED.**

#### **Infrared Heat. Instantaneous Results.**

The Model 4555 High Density Infrared Panel heater is a modular, panel-type heating unit that combines radiant and convection heating techniques. A forced air flow system turns waste heat into usable energy and allows the heater to operate efficiently at very high power levels. This heater is available with either medium-wavelength or short wavelength lamps. You also have the choice of a ceramic reflector or an aluminum reflector.

#### **Applications**

- Activating Thermo Transfer
- Ceramic Processing
- Cure and Melt Powders
- Curing
- Dry and Cure Paint
- Dry Adhesive
- Drying Coatings
- Laminating Composites
- Pre-Cure
- Preheating
- Resin Curing
- Soldering/ Desoldering
- Structural Tests
- Thermoforming
- Thick Film Drying
- Vulcanizing
- Weld Stress Relief

**FAST. FOCUSED. CONTROLLED**

**Features and Benefits-PanelIR 4555**

- The lamps of these heaters heat up and cool down instantly in response to power control signals.
- They reach 90 percent of full operating temperature within three to six seconds of a cold start, depending on the lamps you use.
- The radiant energy dissipates to ten percent five seconds after the power supply is disconnected.
- Localized heat focuses only on the desired area without heating the rest of the product.
- The construction of these heaters, combined with air-cooling, allows them to withstand continuous high temperature operation.
- Non-contact heat source does not come in contact with product being heated.
- The infrared energy emitted from these heaters can be adjusted to match the heating requirements of a variety of applications.
- Repeatable results can be achieved for consistent process outputs.
- Research Inc. manufactures a complete line of process control instruments and SCR power controllers to control the operation of these heaters.
- The Model 4555 is modular in design allowing for multiple units to be installed side-by-side to create large areas of continuous heat output.

**Product Drawing-PanelIR 4555 with Controller**

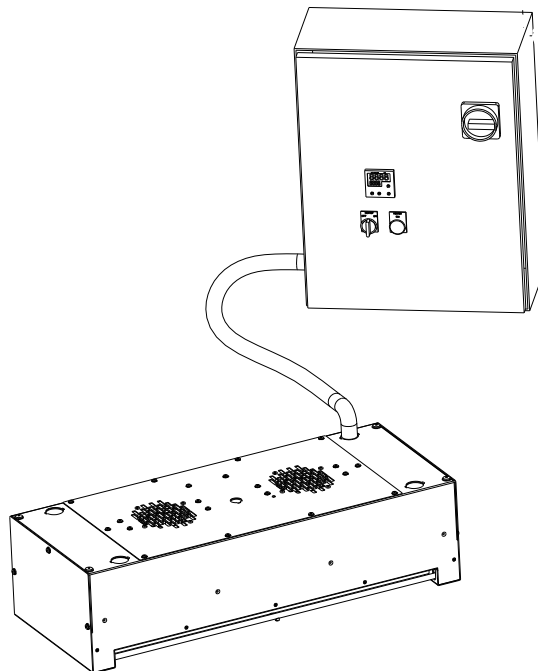

## **Product Description-PanelIR 4555**

### **Heater Construction**

#### **Metal Housing**

The Model 4555 PanelIR uses rugged aluminum housing to contain the lamps, blowers and reflector.

#### **Reflector**

A polished aluminum or ceramic reflector is installed in the housing in back of the lamps to direct the heat toward the product. The choice of ceramic or polished aluminum is based on the application.

#### **Polished Aluminum Reflector**

Polished Aluminum Reflectors are the most commonly used. They have a lower thermal mass than ceramic and as a result, they allow the heater to respond quicker to changes in the lamp temperature.

#### **Ceramic Reflector**

A ceramic reflector is generally used for applications where smoke or dirt are released as a part of the process. These contaminants will burn off of the ceramic reflector during operation so the reflector will not require cleaning.

The ceramic reflector is heavier than a polished aluminum reflector and has more thermal mass to it to take as much as 10 seconds to heat up to operating temperature and to cool down when the lamps are shut off.

#### **Forced Air Blowers**

Blowers are installed in the housing behind the reflector. The blowers pressurize the chamber behind reflector and force air through the holes in the reflector to enhance the heating capability of the panel and to cool the end seals on the lamps.

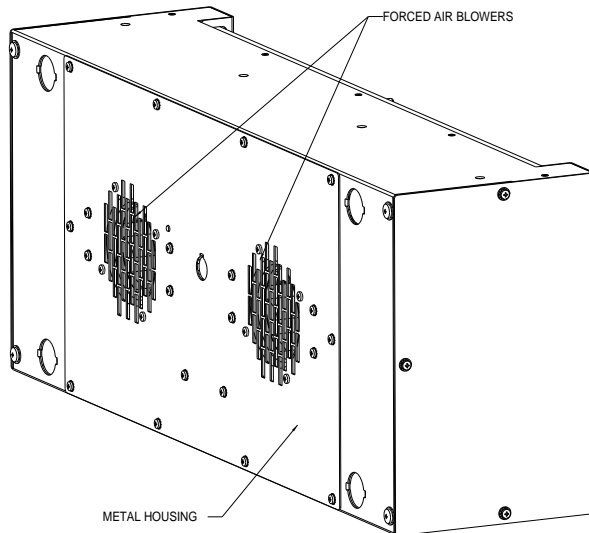

**Product Description-PanelIR 4555 cont.**  
**Heater Construction cont.**

**Infrared Lamps**

**Short Wavelength Lamp**

These lamps are generally used in applications where a product is to be heated or cured. These lamps may be operated in horizontal or vertical orientations. Typical short wavelength applications include:

- Heat treating metals
- Annealing metals
- Spot welding metals and plastics
- Localized softening plastics for bending or forming
- Curing silicone and other rubber extrusions

**\*Limitations**

Absorption of short wavelength is affected by product color. Black and dark colors absorb well. Heating lighter colors may be more readily achieved with medium wavelength lamps.

**Medium Wavelength Lamps**

These lamps are generally used in applications where a surface needs to be dried. They may only be operated in a horizontal orientation.

- High speed drying of water or solvent based ink
- Removing water after coil coating
- Heating substances such as Teflon that do not absorb short wavelength
- Heating lighter colored surfaces

**\*Limitations**

Medium wavelength does not penetrate as deeply into metals, plastics, or rubber as short wavelength. They may only be operated in a horizontal orientation.

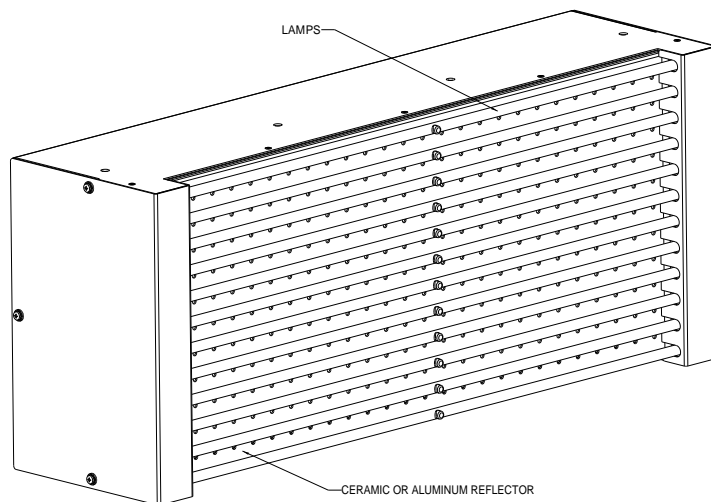



**Infrared Heaters For Controlled Concentrated Heating.**

**Product Description-PanellR 4555 cont.**

**Controls**

The model 4555 PanellR heater is designed to be powered by one of the standard Research Inc. control panels. The model of the control panel required depends on (1) the voltage and amperage required to power the panel, (2) the electrical service in the facility, and (3) the type of temperature control required for the process.

The 900 series control panels are for single phase power and the 925 series panels are for three phase power. Both series can be specified with circuit breakers from 20 amps to 60 amps and with manual or set point control.

Terminal blocks inside the panel allow convenient termination for incoming power, all lamps and the forced air blower. A step down transformer is included in the 440 volt panel to power the 220 volt blowers.

**Power Controller Chart for Model 4555 PanellR**

This chart shows the control panels that are available for all sizes of the Model 4555 PanellR heater.

Heater Module	Power Controller		
	240 Volt 1 Phase	240 Volt 3 Phases	480 Volt 3 Phase
Model 4555-05-06	900-240-20		
Model 4555-05-12	900-240-40	925-240-30	
Model 4555-10-06	900-240-40	925-240-30	
Model 4555-10-09	900-240-40	925-240-30	
Model 4555-10-12	900-240-60	925-240-30	
Model 4555-16-06	900-240-60	925-240-30	925-480-30
Model 4555-16-09		925-240-60	Not Available
Model 4555-16-12		925-240-60	925-480-30
Model 4555-25-06			925-480-30
Model 4555-25-09			925-480-30
Model 4555-25-12			925-480-60
Model 4555-38-06			925-480-30
Model 4555-38-09			925-480-60
Model 4555-38-12			925-480-80

**Technical Information – PanelIR Model 4555**

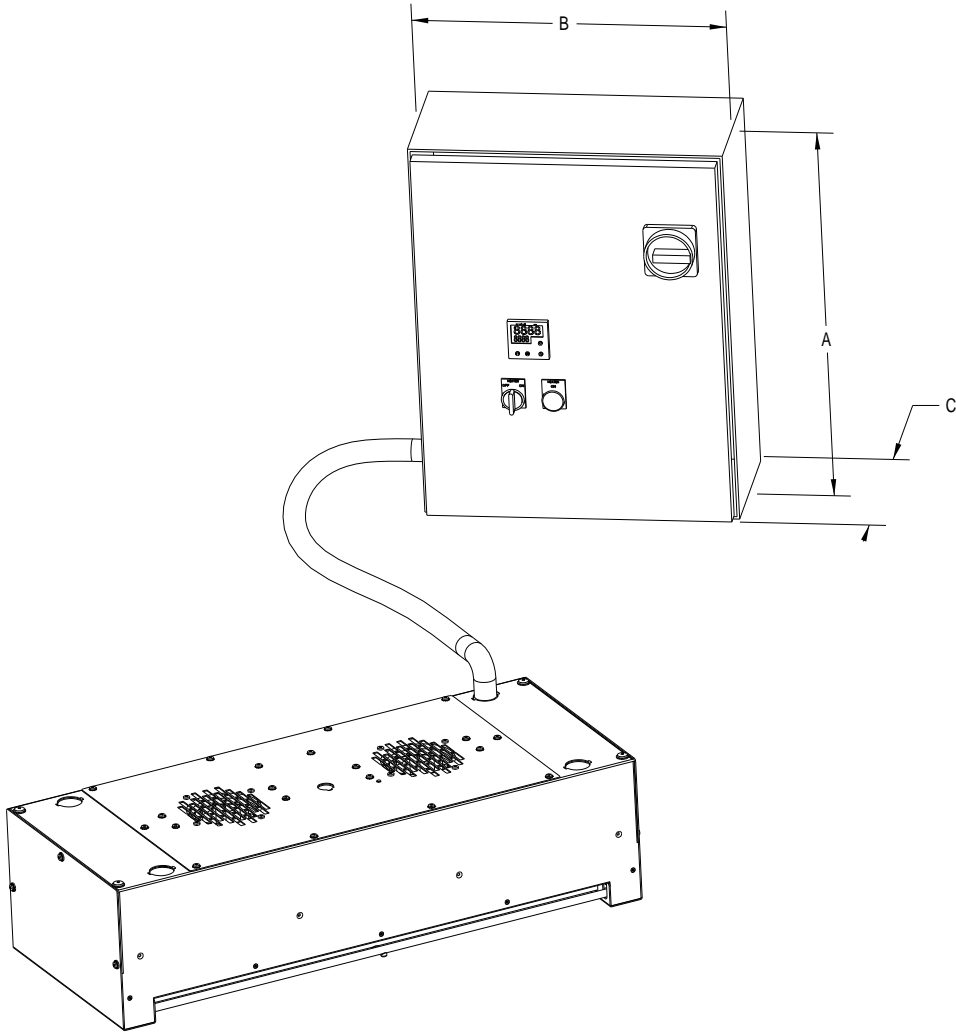



**Infrared Heaters For Controlled Concentrated Heating.**

**Product Description-PanellR 4555 cont.**

Control Panel	Voltage	Circuit Breaker	Dimensions		
			A	B	C
<b>Single Phase</b>					
Model 900-240-20	240 Volt	20 amp	20 inch	16 inch	8.62 inch
Model 900-240-40	240 Volt	40 amp	20 inch	16 inch	8.62 inch
Model 900-240-60	240 Volt	60 amp	20 inch	16 inch	8.62 inch
<b>Three Phase</b>					
Model 925-240-30	224 Volt	30 amp	20 inch	20 inch	8.62 inch
Model 925-240-60	240 Volt	60 amp	24 inch	24 inch	12.62 inch
Model 925-480-30	480 Volt	30 amp	20 inch	20 inch	8.62 inch
Model 925-480-60	480 Volt	60 amp	24 inch	24 inch	12.62 inch
Model 925-480-80	480 Volt	80 amp	24 inch	24 inch	12.62 inch

**Control Options**

All panels have an operator interface that allowed the heater to be controlled in any one of three operator selected modes.

**Manual Operation**

The digital control is used to directly set the percent output of the lamps from 0 to 100%.

**Automatic-Temperature Control**

The controller takes the input from a type "K" thermocouple or IR sensor and regulates the lamp output so the product temperature will match the preset value.

**Automatic-Line Speed**

The controller will take the output from a 0 to 10 VDC line that references line speed and vary the lamp output from 0 to 100% proportionally.

Once you have determined the appropriate size Model 4555 PanelIR Heater, please refer to the Power Controller to select the correct controller for your application.



**SPECIFICATIONS – PanelIR 4555**

MODEL	Lighted Length	Dimension A	Dimension B	Dimension C	Dimension D
Model 4555-05-06	5 (127)	9.28	8.58	6.00	5.375
Model 4555-05-12	5 (127)	9.28	8.58	12.00	10.75
Model 4555-10-06	10 (254)	14.28	13.58	6.00	5.375
Model 4555-10-09	10 (254)	14.28	13.58	9.00	8.375
Model 4555-10-12	10 (254)	14.28	13.58	12.00	10.75
Model 4555-16-06	16 (406)	20.28	19.58	6.00	5.375
Model 4555-16-09	16 (406)	20.28	19.58	9.00	8.375
Model 4555-16-12	16 (406)	20.28	19.58	12.00	10.75
Model 4555-25-06	25 (636)	29.28	28.58	6.00	5.37
Model 4555-25-09	25 (636)	29.28	28.58	9.00	8.375
Model 4555-25-12	25 (636)	29.28	28.58	12.00	10.75
Model 4555-38-06	38 (965)	42.28	41.58	6.00	5.375
Model 4555-38-09	38 (965)	42.28	41.58	9.00	8.375
Model 4555-38-12	38 (965)	42.28	41.58	12.00	10.75

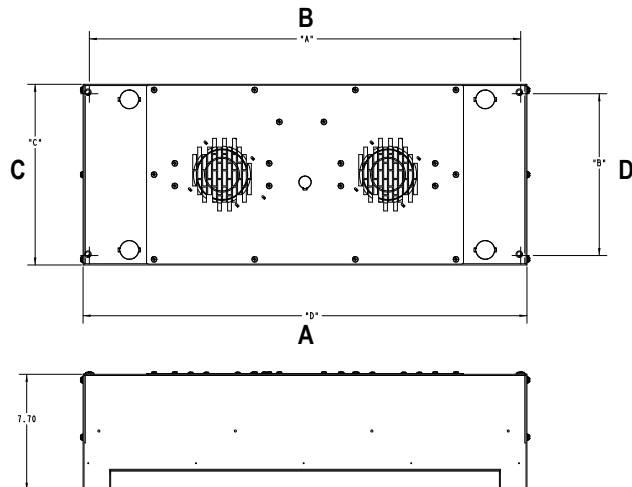
**Dimensions – PanelIR 4555**





**Infrared Heaters For Controlled Concentrated Heating.**

## How to Order – PanelIR Model 4555

### 1. First Specify the heater Module

PRODUCT DESCRIPTIONS PanelIR Model 4555	
Model	Description
4555	PanelIR High Density Area Infrared Heater w / fan (s) Pressure Switch and Thermostat
<b>Code</b>	<b>Length</b>
5	5 inches (127mm)
10	10 inches (254 mm)
16	16 Inches (406 mm)
25	25 Inches (635 mm)
38	38 Inches (965 mm) Short wave lamps only
<b>Code</b>	<b>Lamp Width</b>
06	6 Inches (152 mm)
09	9 Inches (229 mm)
12	12 Inches (254 mm)
<b>Code</b>	<b>Lamp Type</b>
MW	Medium-Wave
SW	Watt-Short-Wave
<b>Code</b>	<b>Reflector Type</b>
AR	Aluminum Reflector
CR	Ceramic Reflector
<b>Code</b>	<b>Custom Options</b>
00	None

**\* Example: 4555-05-06-SW-AR-00**

### 2. Second – Specify the Power Controller

Heater Module	Power Controller		
	240 Volt 1 Phase	240 Volt 3 Phase	480 Volt 3 Phase
Model 4555-05-06	900-240-20		
Model 4555-05-12	900-240-40	925-240-30	
Model 4555-10-06	900-240-40	925-240-30	
Model 4555-10-09	900-240-40	925-240-30	
Model 4555-10-12	900-240-60	925-240-30	
Model 4555-16-06	900-240-60	925-240-30	925-480-30
Model 4555-16-09		925-240-60	Not Available
Model 4555-16-12		925-240-60	925-480-30
Model 4555-25-06			925-480-30
Model 4555-25-09			925-480-30
Model 4555-25-12			925-480-60
Model 4555-38-06			925-480-30
Model 4555-38-09			925-480-60
Model 4555-38-12			925-480-80

**3. Third – Order the Heater Module and Control Panel \* Example: Model 4555-05-06-SW-AR-00 PanelIR and Model 900-240-20 Power Controller**

## Accessories & Replacement Parts – PanelIR 4555

ACCESSORIES AND REPLACEMENT PARTS PanelIR 4555	
Model	Description
	Set of two edge reflectors for:
ER-4555/4-05	5 inch (127 mm) length
ER-4555/4-10	10 inches (254 mm) length
ER-4555/4-16	16 inches (406 mm) length
ER-4555/4-25	25 inches (635 mm) length
ER-4555/4-38	38 inches (965 mm) length
	<b>Short Wavelength Lamps</b>
103390-001	5 inch, 500 watt
103390-003	10 inch, 1600 watt
103390-005	16 inch, 1000 watt
103390-007	25 inch, 2500 watt
103390-010	38 inch, 3800 watt
	<b>Medium Wavelength Lamps</b>
106656-006	5 inch, 500W
106656-001	10 inch, 1000 watt
106656-003	16 inch, 1875 watt
106656-004	25 inch, 2500 watt
106656-005	38 inch, 3800W
M4555	Additional Operation Manual

### Mounting

The back of the Model 4555 has four 1/4-20 X 1/2 inch screws installed for mounting purposes.

### Optional Edge Reflectors

Edge reflectors are available to restrict the radiant energy to a rectangular area. The edge reflectors are constructed from the same materials used in the heater modules. Edge reflectors are specified in the model number or as accessories (in pairs), ordered separately from the Model 4555 heater. For arrays of multiple hookups, only one set of edge reflectors is required for the array.

## Application Chart

	Application	DryIR™	Chamber®	Extrudel™	LineIR®	PanelIR®	ProfileIR™	SpotI®	StripIR®	Hi-TemplR®
Coatings	Cure and Melt Powders	X	X			X			X	
	Dry and Cure Paints	X	X			X			X	
	Dry Ink	X	X			X			X	
	Dry Adhesives	X	X			X			X	
	Preheating	X	X			X			X	
	Resin Curing	X				X			X	
Composites	Curing					X		X		X
	Filament Welding				X			X		X
	Laminating	X				X			X	
Electronics	Ceramic Processing				X			X		X
	Shrink Insulation	X				X			X	
	Soldering Desoldering				X			X		
	Thick Film Drying	X				X			X	
	Wafer Processing					X		X	X	
Trial Testing	Aerodynamic Heating Simulation									X
	Coupon Tests		X							X
	Structural Tests		X							X
	Thermal Stress tests		X			X				X
Processing	Annealing				X	X		X		X
	Brazing				X					X
	Preheating	X	X		X	X			X	
	Soldering				X			X		
	Spring Stress Relief					X			X	X
	Weld Stress Relief				X			X	X	X
Plastic	Bending				X	X			X	
	Bonding	X			X	X				X
	Preheating	X	X		X	X				X
	Thermoforming	X	X		X	X				X
	Welding				X					
Glossing	Cosmetics					X				X
	Plastic Tubing		X							X
	Soap					X				X
Rubber	Curing		X	X		X	X			X
	Pre-Cure		X	X			X			X

# Products Available from

## Research, Inc.

Research, Inc. is the industry leader in the design, development and manufacture of electric infrared heating components and integrated heating systems. Our products are designed to meet a wide variety of process requirements including the drying, heating, curing, soldering, bonding and annealing of many different materials.

Whether it's one of our standard products or a custom heating system, we are committed to providing solutions to meet our customer's most demanding heating needs. The following types of heaters are available:

### Control IR INFRARED HEATERS

All Model 5420 ControllIR@s have a power cable and plug to connect to a wall receptacle and a terminal block to terminate the wires coming from the heater. They all use a phase angle fired SCR to control voltage.

### Dry IR INFRARED HEATERS

An aluminum reflector and either medium or short-wave lamps provide a band of heat from .5" - 4" wide. Can be used for water-based drying, solvent-based drying and adhesive curing.



### Extrude IR INFRARED HEATERS

The Model 4069E ExtrudeIR curing System uses high intensity infrared lamps and polished aluminum reflectors to deliver heat precisely where it is needed for many curing and drying applications on extrusion lines.

### Lamp IR INFRARED HEATERS

Research Inc. specifies tungsten filament halogen lamps in most of its heaters. Halogen gas is added to the inert lamp gas to increase the life of the lamp. As the heater operates, tungsten slowly evaporates from the filament and is combined with the halogen to create a tungsten halide.

### Chamber IR INFRARED HEATERS

The Research, Inc. chamber heater can be ordered in many different sizes for your specific application.

### Line IR INFRARED HEATERS

A lamp and formed reflector that concentrates heat precisely on a .25" wide line. Excellent for forming plastic, local heat treating and drying ink



### Panel IR INFRARED HEATERS

Designed with either ceramic or aluminum reflectors, the heater can provide consistent heat over a large area. Used for most drying and curing applications.

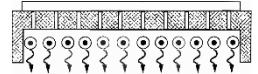

### Profile IR INFRARED HEATERS

The Model 4069 ProfileIR® curing system uses high intensity infrared lamps and polished aluminum reflectors to deliver heat precisely where it is needed to cure irregularly shaped profiles.

It can instantaneously give a surface cure that eliminates marks that occur when uncured rubber rubs on a conveyor.

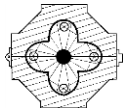

### Spot IR INFRARED HEATERS

A single lamp and reflector heating system that focuses energy on a small (.25") target. Instant on/instant off capability makes it ideal for applications such as soldering, localized heat treating, and stress relieving.

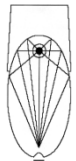

### Strip IR INFRARED HEATERS

A lamp and formed reflector that provides even heat distribution across a 1.7" wide strip. Can be used for curing, drying and precise heating.

