

Model 4085



FAST. FOCUSED. CONTROLLED.

Infrared Heat. Instantaneous Results.

The SpotIR® Model 4085 is designed for use in any application that requires clean, non-contact heat on a small target or object. It is a single lamp and reflector heating system that focuses energy on a small (.25") diameter target.

Applications

- Metal Annealing
- Brazing
- Soldering and Desoldering Electronic Components
- Solder Termination
- Filament Winding
- Activating Thermo Transfer
- Bonding
- Thermoforming
- Welding
- Heat Staking



Infrared Heaters For Controlled Concentrated Heating.

FAST. FOCUSED. CONTROLLED.

Features and Benefits SpotIR Model 4085

- The lamp reaches 90 percent of full operating temperature within three seconds of a cold start.
- The radiant energy dissipates to ten percent five seconds after the voltage from the power supply is turned off.
- Localized heat focuses only on the desired area without heating the rest of the product.
- The construction of this heater, combined with air-cooling, allows it to withstand an 100% duty cycle over 30 minutes.
- Non-contact heat source does not come in contact with product being heated.
- The infrared energy emitted from this heater can be adjusted to match the heating requirements of a variety of applications.
- Repeatable results can be achieved for consistent process outputs.
- The power controller required to control this heater is included as a part of the package.

Product Description SpotIR Model 4085

The product is comprised of two major components, the heater module and the power controller.

Heater Module

The Model 4085 SpotIR module is 7.22 inches long without a reflector shield. It contains a 750 watt lamp and a reflector that focuses the infrared energy on a 0.25 inch diameter spot that is located 4.03 inches from the end of the heater body. The heater module has an attached power cord and a ¼ inch NPT fitting to accept a ¼ inch air line. 10 feet of tubing included.

Standard Full Shield Reflector

The heater module ships with a full shield reflector. This reflector has a 0.54 inch diameter hole in the end which should be located around the spot to be heated. Alternate reflector shields may be ordered separately. See figure #3 for actual focal point location.

Air Cooling

An air intake fitting is supplied on the Model 4085 for connection of proper cooling air supply. Clean shop air can be provided through the air intake fitting to cool the heater for extended duty applications. The air is directed to the lamp socket and then around the rear side of the reflector to be exhausted around the rim of the reflector. Cooling air should be clean, oil-free and at 100°F (38°C) or less. Airflow rates required to operate the heater, and recommended duty cycles with and without air-cooling, are listed in Specifications.

Mounting

Two ¼"-20 by 3/8 inch (9.5 mm) deep tapped holes are provided for properly mounting the Model 4085. See figure #3 for mounting hole locations.



RESEARCH INC.
PROVIDING CONTROLLED ENERGY
DRYING • CURING • HEATING

7128 Shady Oak Road, Eden Prairie, MN 55344 • USA
Phone 952.949.9009 • Fax 952.949.9559 • www.researchinc.com

Product Description-SpotIR 4085 continued

Power Controllers

The Model 4085 Heater comes wired into a power controller to precisely regulate the voltage being applied to the heater. The output of the heating element is very repeatable and is dependent on the voltage supplied to it. The power controllers are designed as part of this system to optimize the heater performance. The controllers can be ordered with one of several command signal options to allow you to choose how the heat output is controlled. The controller options for the SpotIR Model 4085 are:

Model 5420 Power Controller

The Model 5420 Power Controller has an off/on switch and a manual one-turn potentiometer that will vary the output voltage form 0% to 97% of the line voltage. The controller comes complete with a power cord and plug and a terminal block connection to install the wiring from the heater.

Model 5420E Power Controller

The Model 5420E Power Controller has an off/on switch, a manual one-turn potentiometer that will vary the output voltage form 0% to 97% of the line voltage and a timer. The time has a 50 increment dial and may be set to adjust the voltage on time between 0 to 5.0 sec. 0 to 50 sec, 0 to 5.0 min, 0 to 50min, 0 to 5.0 hour and 0 to 50 hour. The controller comes complete with a power cord and plug and a terminal block connection to install the wiring from the heater.

Model 5420mA Power Controller

The Model 5420mA Power Controller has an off/on switch and a receptacle/plug to accept a 4 to 20 mA control signal from an external source to regulate the output voltage. The controller comes complete with a power cord and plug and a terminal block connection to install the wiring from the heater.

Product Drawing – SpotIR Model 4085

Figure 1: SpotIR Model 4085 Product Drawing / Featuring Controller Model Number 5420

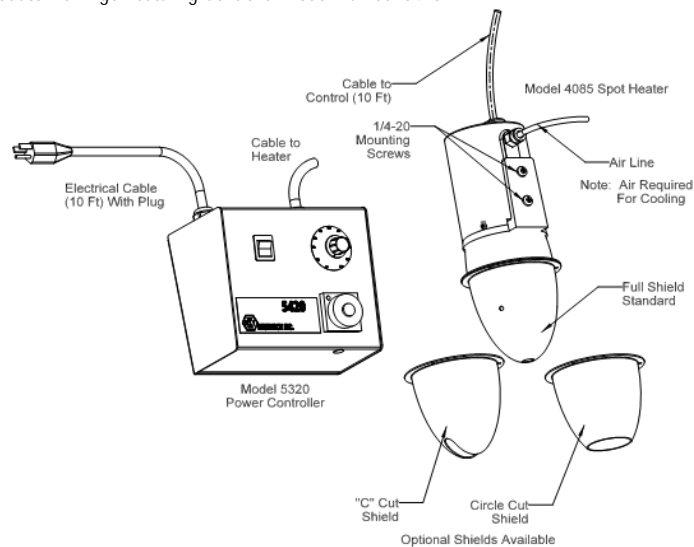

Model 5420 120 VAC Power Controller

Technical Information

Heat Flux Densities

The heat flux generated at the focal point can be as high as 650 watts per square inch (101 watts per square cm) at the center of the focal point with a full shield. 200 watts per square inch (31 watts per square cm) without a shield.

SpotIR Model 4085 Heat Flux Density for Shield Options

Figure #2

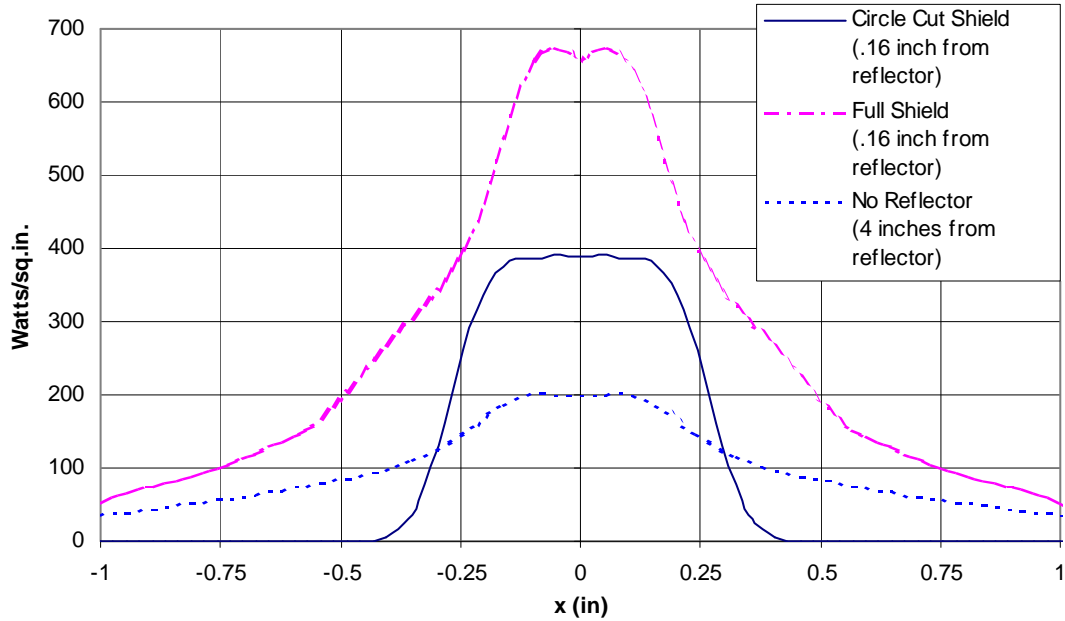

SpotIR Model 4085 Dimensions

Figure #3

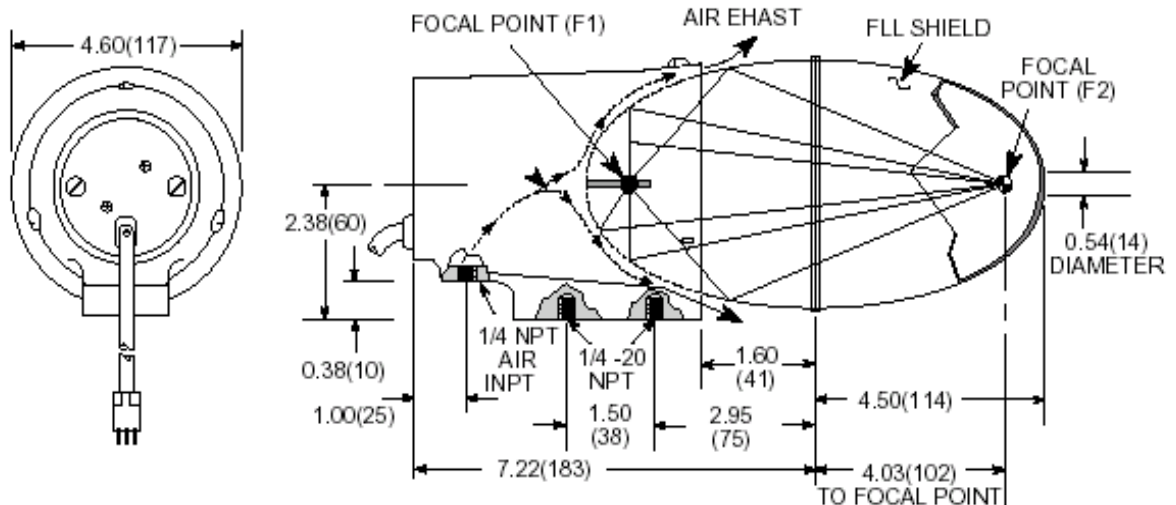

Additional Components and Accessories

Reflector Shield for SpotIR Model 4085

A full shield reflector is supplied with the Model 4085 to contain the infrared energy within the desired target area. Two additional types of reflector shields are available to accommodate a variety of heating applications. All three shield types are shown in Figure#4. If a particular shield interferes with objects near the target being heated, it can be changed easily to fit the application. The reflector shield is attached to the heater module with three screws. Additional shields can be purchased so that a single heater can be used for a variety of applications.

SpotIR Model 4085 Shield Dimensions

Figure #4

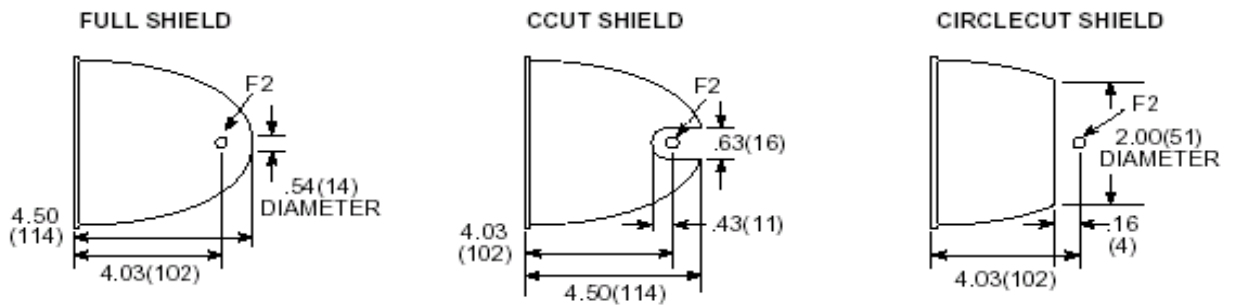



Infrared Heaters For Controlled Concentrated Heating.

Specifications – SpotIR Model 4085

SPECIFICATIONS	
Lamp Type	750Q/CL
Total Power Dissipated at 120 Volts	750
Current, Ampress	6.3
Approximate Focal Point Diameter, Inches (mm)	0.25 (6)
Heat Flux Density at Target Surface Without Shield, Watts/Sq In. (W/sq. cm)	200 (31)
Heat Flux Density at Target Surface With Shield, Watts/Sq In. (W/sq. cm)	650 (101)
Duty Cycle Without Air Cooling, "On" Time, Percent of Duty Cycle	35 %
Duty Cycle Without Air Cooling, Maximum "On" Time Minutes	6
Duty Cycle With Air Cooling, "On" Time, Percent of Duty Cycle	100%
Cooling Air Required	120 SCFH
Emitter Life	500 hrs. @120

How to Order - SpotIR Model 4085

PRODUCT DESCRIPTIONS	
4085-00-750-00-00	4085, 750W Lamp, No controller
4085-00-750-01-00	4085, 750W Lamp, Model 5420-120 controller (includes potentiometer)
4085-00-750-02-00	4085, 750W Lamp, Model 5420E-120 controller (includes pot, and timer)
4085-00-750-03-00	4085, 750W Lamp Model 5420MA-120 controller (includes 4-20 mA input control)

Accessories and Replacement Parts - SpotIR Model 4085

ACCESSORIES and REPLACEMENT PARTS	
057550-006	Halogen lamp, 750 watt, (sold in pairs)
032914-000	Reflector shield, full-cut (interchangeable with internal reflector) (A)
034900-000	Reflector shield, circle cut (B)
034901-000	Reflector shield, C-cut (C)
4085-750	Model 4085-750 SpotIR heater module
5420-120	Model 5420-120 power controller (includes potentiometer)
5420E-120	Model 5420E-120 power controller (includes pot., and timer)
5420mA-120	Model 5420 mA-120 power controller (includes 4-20 mA input control)



Application Chart

	Application	DryIR™	ChamberI®	Extrudel™	LineIR®	PanelIR®	ProfileIR™	SpotI®	StripIR®	Hi-TempIR®
Coatings	Cure and Melt Powders	X	X			X			X	
	Dry and Cure Paints	X	X			X			X	
	Dry Ink	X	X			X			X	
	Dry Adhesives	X	X			X			X	
	Preheating	X	X			X			X	
	Resin Curing	X				X			X	
Composites	Curing					X		X		X
	Filament Welding				X			X		X
	Laminating	X				X			X	
Electronics	Ceramic Processing				X			X		X
	Shrink Insulation	X				X			X	
	Soldering Desoldering				X			X		
	Thick Film Drying	X				X			X	
	Wafer Processing					X		X	X	
Trial Testing	Aerodynamic Heating Simulation									X
	Coupon Tests		X							X
	Structural Tests		X							X
	Thermal Stress tests		X			X				X
Processing	Annealing				X	X		X		X
	Brazing				X					X
	Preheating	X	X		X	X			X	
	Soldering				X			X		
	Spring Stress Relief					X			X	X
	Weld Stress Relief				X			X	X	X
Plastic	Bending				X	X			X	
	Bonding	X			X	X				X
	Preheating	X	X		X	X				X
	Thermoforming	X	X		X	X				X
	Welding				X					
Glossing	Cosmetics					X				X
	Plastic Tubing		X							X
	Soap					X				X
Rubber	Curing		X	X		X	X			X
	Pre-Cure		X	X			X			X

Products Available from Research, Inc.

Research, Inc. is the industry leader in the design, development and manufacture of electric infrared heating components and integrated heating systems. Our products are designed to meet a wide variety of process requirements including the drying, heating, curing, soldering, bonding and annealing of many different materials.

Whether it's one of our standard products or a custom heating system, we are committed to providing solutions to meet our customer's most demanding heating needs. The following types of heaters are available:

Control IR INFRARED HEATERS

Control Systems designed for operation of the many standard Research Inc. Heater products. We can also custom build a control solution to meet your factory/application needs.

Dry IR INFRARED HEATERS



An aluminum reflector and either medium or short-wave lamps provide a band of heat from .5" - 4" wide. Can be used for water-based drying, solvent-based drying and adhesive curing.

Extrude IR INFRARED HEATERS

The Model 4069E ExtrudeIR curing System uses high intensity infrared lamps and polished aluminum reflectors to deliver heat precisely where it is needed for many curing and drying applications on extrusion lines.

Lamp IR INFRARED HEATERS

Research Inc. specifies tungsten filament halogen lamps in most of its heaters. Halogen gas is added to the inert lamp gas to increase the life of the lamp. As the heater operates, tungsten slowly evaporates from the filament and is combined with the halogen to create a tungsten halide.

Chamber IR INFRARED HEATERS

The Research, Inc. chamber heater can be ordered in many different sizes for your specific application.

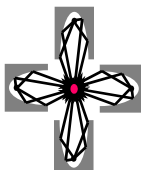

Line IR INFRARED HEATERS

A lamp and formed reflector that concentrates heat precisely on a .25" wide line. Excellent for forming plastic, local heat treating and drying ink



Panel IR INFRARED HEATERS

Designed with either ceramic or aluminum reflectors, the heater can provide consistent heat over a large area. Used for most drying and curing applications.

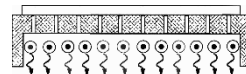

Profile IR INFRARED HEATERS

The Model 4069 ProfileIR® curing system uses high intensity infrared lamps and polished aluminum reflectors to deliver heat precisely where it is needed to cure irregularly shaped profiles.

It can instantaneously give a surface cure that eliminates marks that occur when uncured rubber rubs on a conveyor.

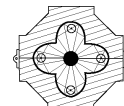

Spot IR INFRARED HEATERS

A single lamp and reflector heating system that focuses energy on a small (.25") target. Instant on/instant off capability makes it ideal for applications such as soldering, localized heat treating, and stress relieving.

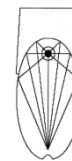

Strip IR INFRARED HEATERS

A lamp and formed reflector that provides even heat distribution across a 1.7" wide strip. Can be used for curing, drying and precise heating.

