

**Model 930
Power Control System
Instruction Manual**

Publication No. A105328-001 Rev A



December 2000

Another quality product from:



7128 Shady Oak Rd, Eden Prairie MN 55344

Phone: (952) 949-9009 Fax: (952) 949-9559

www.researchinc.com



Dear Customer:

Thank you for purchasing a Model 930 ControlIR™ Power Control System. We believe it is the finest system of its type and are confident you will think so too.

For technical assistance, training, replacement parts and assemblies, or any other problems or questions, contact our Field Service specialists. They will do everything they can to help you or will put you in touch with someone who can.

This instruction manual has been carefully prepared to make sure you get out of your system all the capabilities we designed and built into it. To tell us how we could make the system, our support of it, or this manual even more useful, we invite you to call our product manager with your suggestions and recommendations.

Additional copies of this manual are available at a reasonable cost from our Customer Service Department.

Once again, let us welcome you to the growing family of Research, Inc. customers. We look forward to working with you in the future.

Sincerely,

Terry Nigon
President
Research Inc.

<u>Section</u>	<u>page</u>
INTRODUCTION	
General Description.....	1
Standard Features.....	1
Optional Features.....	2
SAFETY	3
INSTALLATION	
Mounting the System.....	4
Wiring Connections.....	5
Power Wiring Connections.....	6
Line Connections.....	6
Load Connections.....	6
Control Connections.....	6
Cooling Flow On/Off Relay Output.....	6
Cooling Flow Switch Interlock.....	7
Heater Over-Temperature Thermo-switch Interlock.....	7
Remoter Interlock Switch.....	7
Heater Open Switch Interlock.....	7
Remote Setpoint Input.....	8
Temperature Control Option Connections (Option Codes TCT & TCP).....	9
OPERATING INSTRUCTIONS	
Controls and Indicators.....	10
Main Disconnect Switch.....	10
Heater ON/OFF Switch.....	10
Cooling ON/OFF Switch.....	10
Heater On Indicator.....	10
Cooling On Indicator.....	10
Heater Over Temperature Indicator.....	10
Lamp-Out, OCT / SCR Indicator.....	10
Remote/Local Setpoint Switch.....	11
Local Setpoint Potentiometer.....	11
Load Volts Indicator (Option Code VM).....	11
Temperature Control Option.....	12
Setup Summary.....	12
Theory of Operation.....	12
Principles of SCR Power Control.....	12
Principles of Phase Angle Control.....	12

**MAINTENANCE AND
TROUBLE SHOOTING**

Routine Maintenance.....	16
Troubleshooting.....	16
Calibration.....	17
Power Controller.....	17
Panel Voltmeter Calibration.....	18
Temperature Controller Option.....	18
Line Voltage Re-Configuration.....	19

**DIMENSIONS AND
SPECIFICATIONS**

Specifications.....	20
Dimensions.....	22
Ordering Information.....	24
Ordering Example.....	24
Spare and Replacement Parts.....	25

Introduction

GENERAL DESCRIPTION

The Model 930 power control system is a complete power 'solution' featuring a number of elements integrated into a single, ready-to-install package. The Model 930 is a three-phase power control system available in two configurations of 120 and 160 Amps at 480 Volts. These systems are ideally suited for many industrial power control applications and have been specifically optimized for use with Research Inc. infrared heating systems.

Figure 1-1 Model 930
Three Phase Power
Controller



STANDARD FEATURES

Standard features include:

- Local 10 turn potentiometer with digital dial for precise manual control of load voltage.
- Remote control capability with a 0-5 VDC or 0-20 mA signal.
- Heater power switch with remote interlocks. The load voltage may be enabled or disabled without turning off the main disconnect switch.
- Heater ON/OFF switch controls an AC contactor to remove power from the SCR controller and the load.
- Cooling power switch to control air or water cooling flow.
- Cooling flow interlock contacts. Low cooling turns off the heater contactor.
- Heater open interlock contacts. A heater open condition turns off the heater contactor.
- Heater over temperature contacts. Heater over temperature condition turns off the heater contactor.
- Indicators lights for heater on, cooling on, heater over temperature, and SCR fault condition.

- Fail safe operation of the heater contactor. The contactor will not automatically re-energize after a power failure, or an alarm condition that shuts down the heater.
- Programmable Logic Controller for operating and alarm logic control.

OPTIONAL FEATURES

The following standard options are available:

Automatic Temperature Control Option

The automatic temperature control option allows the power level to be adjusted based on an entered temperature setting for the process. The temperature controller uses PID type control and is pre-wired for a 'K' type thermocouple (option code TCT) or a 4/20mA pyrometer signal (option code TCP).

Voltmeter Option

The true RMS load voltage is displayed with a digital meter. A true RMS voltage transmitter is provided for isolation and operator safety.

Lamp-out Detection Option

The lamp out detection option is designed to detect a lamp failure or load loss when using multiple infrared heaters or zones of lamps in a single heater. The SCR fault / Lamp out indicator flashes during this condition.

Product Detect "PD" Option

The product detect option automatically adjusts the heater or lamp intensity between run and idle states when a product is detected on the conveyor. A single turn idle potentiometer is provided on the front panel. Idling the process saves energy and equipment wear.

Safety

WARNING!

Hazardous voltages are present at the main disconnect switch and load terminals. Setting the setpoint potentiometer or control signal to minimum does NOT eliminate these hazardous voltages.

Always remove AC line voltage from the system before making contact with internal assemblies, line or load wiring, or fuses. Also remove AC line voltage from the system before making connections, equipment changes, or resistance measurements.

CAUTION!

Up to 480 volts AC is present within the power control solution system.

Do not make any wiring connections when power is applied.

Disconnect power before performing any maintenance or service to the system.

Use extreme caution when adjusting calibration potentiometers on modules when power is applied.

Always use an isolated oscilloscope for checking waveforms.

Installation

This section describes how to install and wire the Model 930 power control system. The features and options mentioned here are identified in the model number found inside the enclosure.

WARNING!

Hazardous voltages are present at the main disconnect switch and load terminals. Setting the setpoint potentiometer or control signal to minimum does NOT eliminate these hazardous voltages.

Always remove AC line voltage from the system before making contact with internal assemblies, line or load wiring, or fuses. Also remove AC line voltage from the system before making connections, equipment changes, or resistance measurements.

MOUNTING THE SYSTEM

The Model 930 Power Control System may be mounted to a wall with the supplied brackets, on a stand, or bench. The Model 930 must be mounted in a vertical position. When mounting to a wall, the top of the enclosure should not be over 74 inches (1880 mm) above the floor.

Figure 3-1 Wall Mounting Dimensions

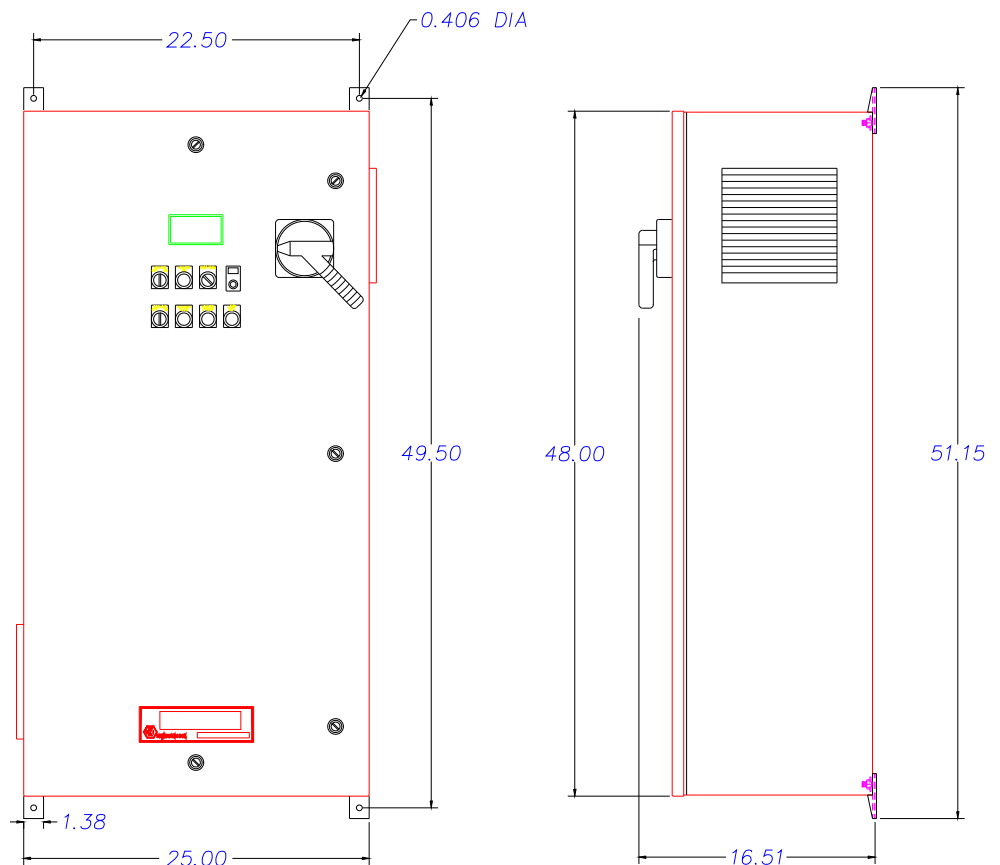

The weight of the Model 930 varies slightly with the options installed. The maximum weight of the system is ???.

WIRING CONNECTIONS

Conduit entry into the system should be made near the right side of the cabinet for power wiring, near the center of the cabinet for load wiring, and near the left side for low voltage control wiring. Assure that metal fragments are not allowed to fall into the equipment while holes are made for conduit fittings.

We suggest a separate conduit entry should be made for low level DC control wiring if used. This includes the remote setpoint input or thermocouple wire (temperature control option).

Table 3-1 Wiring Specifications

Wire Ratings:

Wire Temperature Rating:	75°C or Higher
Line/Load Wiring Voltage Rating (240 VAC systems)	300 VAC Minimum
Line/Load Wiring Voltage Rating (480 VAC systems)	600 VAC Minimum
Control Wiring	300 VAC Minimum

Allowable Wire Sizes:

Current Rating of System	Line Connections	Load Connections	Ground Connection	Control Circuit Connections
120 Amp	#6-250 MCM	#6-250 MCM	#4-1/0 AWG	22-10 AWG
160 Amp	#6-250 MCM	#6-250 MCM	#4-1/0 AWG	22-10 AWG

Recommended Minimum Wire Sizes:

NOTE:

Wire temperature and connector ampacity ratings are based on NEC 310-16 using 75 °C copper wire derated for 50 °C ambient environment.

Current Rating of System	Line Connections	Load Connections	Ground Connection	Control Circuit Connections
120 Amp	1 AWG	6 AWG	6 AWG	16 AWG
160 Amp	2/0 AWG	4 AWG	6 AWG	16 AWG

Electrical Inputs:

Heater open interlock switch	Contacts Rated for 120 VAC at 2.0 A
Cooling flow interlock switch	Contacts rated for 120 VAC at 100 mA
Heater over-temp. thermoswitch	Contacts rated for 120 VAC at 100 mA
Remote interlock switch	Contacts rated for 120 VAC at 100 mA

Power Wiring Connections

Line Connections

Referring to the wiring specification in Table 3-1, connect the external power lines to the top of the disconnect switch.

Load Connections

The model 930 power control system has 2 (3-pole) load fuseblocks for distributing the Three-phase power to your process. For the 120 Amp systems, do not exceed more than 60 amps – 3 phase per fuseblock. For the 160 Amp systems, do not exceed more than 80 amps – 3 phase per fuseblock. The heater load should be wired to evenly distribute the number of individual lamps or heating elements to the 2 (three phase) load circuits. It is suggested to balance the load circuits by having the same number and size of lamps or heating elements per phase and per load circuit.

Figure 3-2

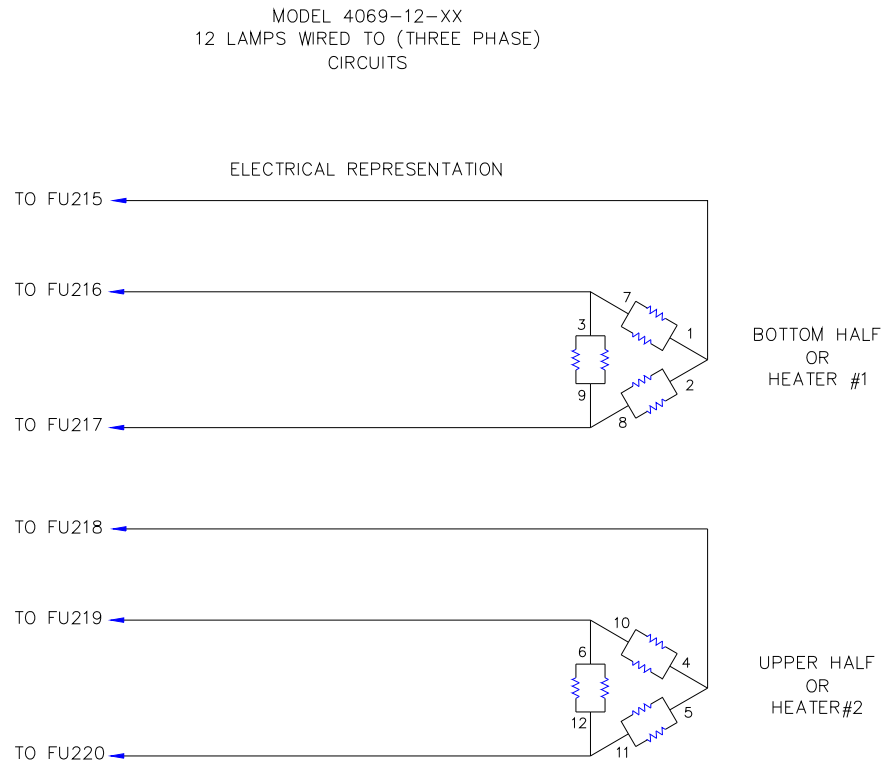

CONTROL CONNECTIONS

Refer to Figure 3-3 for connection of the following items.

Cooling Flow On/Off Relay Output

This feature provides a normally closed and open (form C) dry contact relay output to control cooling flow.

Connect the cooling solenoid /chiller/contactor circuit to TB-100 pins 24 (NC), 25 (COM), 26 (NO) as required.

Cooling Flow Switch Interlock

This feature provides shutdown of the heater power in case of low or no cooling flow. This is accomplished by opening the heater power controller contactor. The cooling sensor may be a water flow or air flow switch. Use a switch with contacts that are open during the fault condition.

Connect the flow switch to TB 100 pins 2 and 3. If both water and air cooling flow switches are used in a system, wire the switches in series and then connect to the system.

Heater Over-Temperature Thermo-switch Interlock

This feature provides shutdown of the heater power in case of a heater over-temperature. This is accomplished by opening the heater power controller contactor. If a thermo-switch is not included with your heater, use a thermo-switch with contacts that will open during the over-temperature condition. If this feature is desired or provided with the heater, connect using the following procedure:

1. Remove the factory installed jumper at TB 100 pins 4 and 5.
2. Connect the thermo-switch to TB 100 pins 4 and 5.
3. If more than 1 thermo-switch is used, in a system, wire the switches in series and then connect to the system.

Remote Interlock Switch

This feature provides for remote process interlock shutdown of the heater power. This is accomplished by opening the heater power controller contactor. With the interlock open, the heater can not be turned on from the control system front panel. The switch contacts must be open during the heater off condition. If this feature is desired, connect using the following procedure:

1. Remove the factory installed jumper at TB 100 pins 10 and 11.
2. Connect the normally open contacts of the switch to TB 100 pins 10 and 11.
3. If more than 1 interlock switch is used in a system, wire the contacts in series and then connect to the system.

Heater Open Switch Interlock

This feature provides shutdown of the heater power if the heater is opened during operation. This switch directly interlocks power to the heater contactor. If a heater cavity open switch is not included with your heater, use a switch with contacts that are open when the heater is open. To implement feature, connect using the following procedure:

1. Remove the factory installed jumper at TB 100 pins 14 and 15.
2. Connect the normally open contacts of the switch to TB 100 pins 14 and 15.
3. If more than 1 heater open interlock switch is used in a system, wire the contacts in series and then connect to the system.

NOTE:

If a remote Emergency Stop switch is desired, wire the switch (push/pull type with maintained contacts) in series with the heater open switch.

Remote Setpoint Input

This feature allows the power level of the system to be controlled from a remote location or device. This is accomplished by applying a 0-5 VDC or 0-20 mA signal input from a remote source. This feature is not available when the 'Temperature Controller' option is installed. If this feature is desired use the following procedure:

1. For a 0-5 VDC input, connect the source to TB 100 pins 16+ and 17-.
2. For a 0-20 mA input, connect the source to TB 100 pins 16+ and 17-. Also install a 250 ohm resistor across terminals TB 100 16+ and 17-.

Figure 3-3 Control Connections

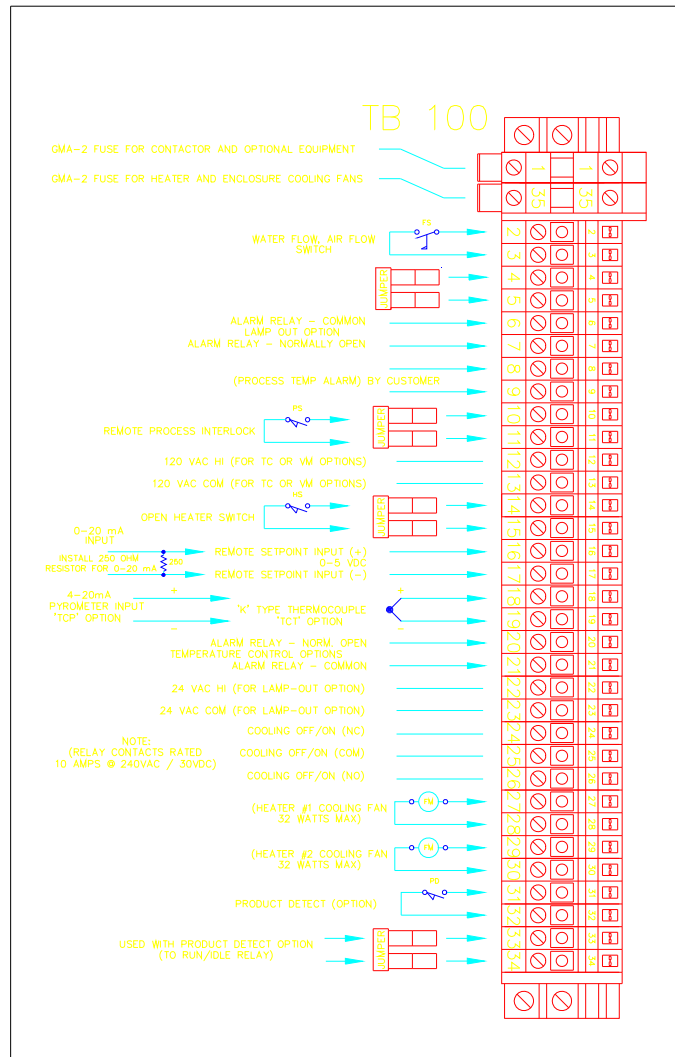

Temperature Control Option Connections (Option Codes TCT & TCP)

Temperature control option 'TCT' is setup to use a 'K' type thermocouple for the temperature input. Temperature control option 'TCP' is setup to use a pyrometer for the temperature input. Alarm connections are provided if required for your process. The alarm contacts are 'dry' type rated for a maximum of 3 Amps resistive at 240 VAC. If desired the process temperature alarm may be connected to the Front Panel Over-Temp Alarm Indicator. Make connections as follows:

1. 'TCT' option: Use 'K' type extension wire from the thermocouple to the system connections. Connect the 'K' thermocouple extension wire to TB 100 pins 18+ and 19-.
2. 'TCP' option: The pyrometer should source the 4-20 mA current through it's circuitry. If a '2 wire' pyrometer is used, an external power supply must be used. The model 935 does *not* source current for pyrometer operation. Connect the 4-20mA signal to TB 100 pins 18+ and 19-.
3. 'TCT' and 'TCP' options: To use the alarm output as an external process alarm. Connect the device for the alarm output to TB100 pins 20 and 21. If a remote alarm output is not used, the alarm may be connected to the front panel over-temp alarm indicator. Connect TB 100 pin 20 to pin 8 and TB 100 pin 4 to pin 11. The alarm indicator will flash while the temperature controller is in an alarm condition.

Operating Instructions

CONTROLS AND INDICATORS

Figure 4-1 shows the location of the controls and indicators.

Main Disconnect Switch

The main disconnect switch turn on and off the power control system. Note the following:

Before turning on the disconnect switch, check the following:

1. The load is wired and ready for power to be applied to it.
2. All safety precautions are observed.

Heater ON/OFF Switch

The Heater ON/OFF switch allows the operator to enable or disable the power going to the load. This is accomplished by removing power from the AC contactor. This in turn removes power from the SCR controller. The cooling on indicator must be on before the heater power can be turned on.

Cooling ON/OFF Switch

The Cooling ON/OFF switch allows the operator to turn on or off the heater cooling.

Heater On Indicator

- Indicator light on steady indicates power is applied to the heater power controller.
- Indicator light flashing indicates that the Remote Interlock is open and heater power can not be applied.

Cooling On Indicator

- Indicator light on steady indicates adequate cooling flow.
- Indicator light flashing indicates that the cooling is in a one minute shutoff delay cycle. The one minute delay cycle is activated any time that the heater power contactor is opened, after the initial heater on cycle is activated.

Heater Over Temperature Indicator

- Indicator light on steady indicates a heater over temperature condition. A heater over temperature condition will open the heater power contactor, removing power from the heater.
- Indicator light flashing indicates a process over temperature alarm. This feature is available only if the Temperature Control Option is installed. The indicator will flash only as long as the process alarm exists.

Lamp-Out, OCT / SCR Indicator

- Indicator light on steady indicates a power controller over current (OCT) or a power controller shorted scr (SCR) condition exists. The OCT / SCR alarm will open the heater contactor, removing power from the load.
- Indicator light flashing indicates a lamp out condition. This feature is available only if the lamp out (LL) option is installed. The alarm will remain on as long as the lamp out condition exists.

Remote/Local Setpoint Switch

The remote/local setpoint switch allows the operator to select the source for the power level setting to the load, lamps, or heaters. The selections include:

1. LOCAL: The power level is adjusted using the digital 10-Turn 'LOCAL SETPOINT' potentiometer.
2. REMOTE: The power level is controlled from a remote location or device or the power level is controlled by the temperature controller if the TCT/TCP temperature option is installed. The operator will enter a desired temperature setpoint for the process. The power level is adjusted based on the feedback from the temperature sensor connected to the process.

Local Setpoint Potentiometer

The power level is adjusted using the digital 10-Turn 'LOCAL SETPOINT' potentiometer when the 'Setpoint' switch is in the 'Local' position.

Load Volts Indicator (Option Code VM)

This option provides indication of the 'True RMS' load voltage.

Figure 4-1 Controls and Indicators

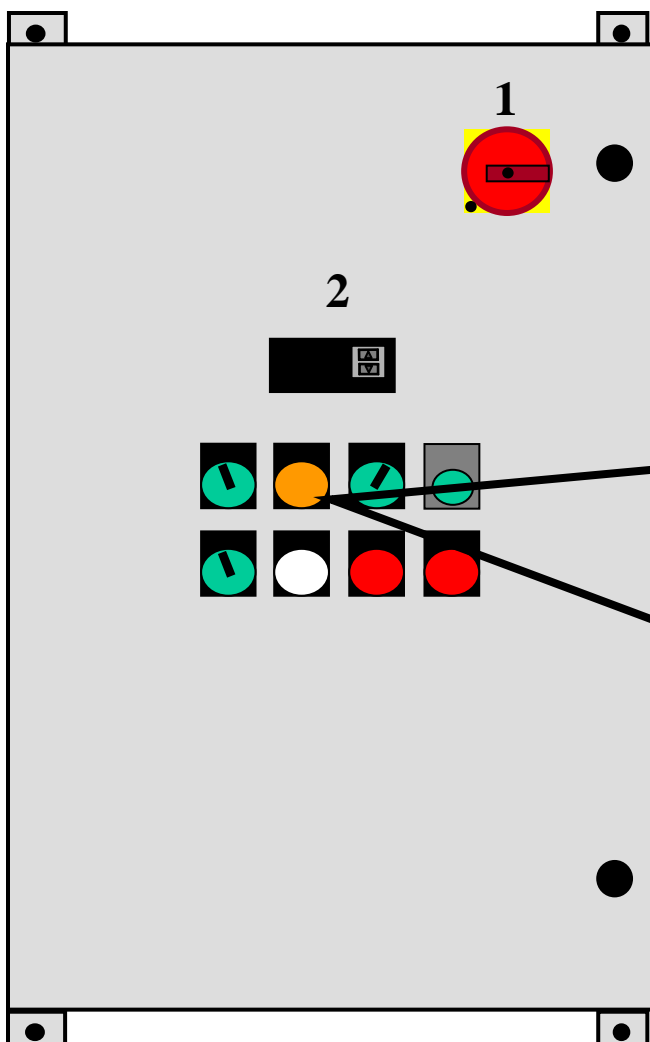

1. Disconnect Switch
2. Optional Temperature Controller or Optional Voltmeter
3. Heater On / Off Switch
4. Heater On Indicator
5. Remote / Local Setpoint Switch
6. Local Setpoint Potentiometer
7. Cooling On / Off Switch
8. Cooling On Indicator
9. Heater Over-Temperature Indicator
10. Over Current / Shorted SCR Indicator and Optional Lamp Out Indicator

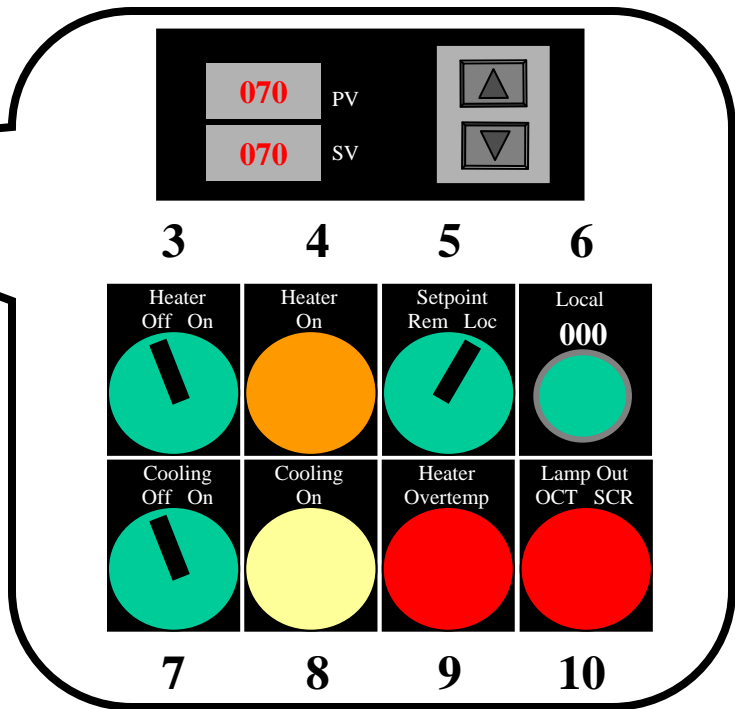

TEMPERATURE CONTROL OPTION

This section contains temperature controller configuration information for your system. Refer to the Model XT19 installation and instruction manual for operating the temperature controller.

Setup Summary

Table 4-1 displays factory configurations made for your system:

Table 4-1 Temperature Controller Configuration

Sensor Input (TCT option)	'K' type thermocouple scaled 0-2500°F
Sensor Input (TCP option)	4-20mA signal scaled 0-2500°F
Control Type:	PID (proportional, integral & derivative)
AL 1 (alarm 1):	Full scale high, non-latching, set for 2000°F (This alarm will trip a relay connected to TB100 pins 13 and 14)
Control Output:	0-20 milliamps
<i>This alarm may be re-configured as necessary for your process</i>	

THEORY OF OPERATION

Principles of SCR Power Control

SCR type power controllers control power by regulating when silicon controlled rectifiers (SCRs) conduct AC line current to the load.

A SCR is a solid-state, electronic switching device that turns on (fires) very quickly when a low-level "gating" signal is applied to its gate electrode. The timing of the gating signal, and therefore the length of time the SCR conducts, is determined by the controller's firing circuitry in response to a control signal. The greater the percentage of time the SCR is on, the greater the average power it allows to pass through to the load.

The Model 910 uses a random-fire solid state relay within its SCR power controller. This relay is a package consisting of 2 SCRs and a gate drive circuit.

During the positive half-cycle of the AC line voltage the SCR's anode is positive with respect to its cathode, so during that half-cycle the SCR will begin to conduct whenever a gating signal is applied to its gate electrode (see figure 4-2). Once turned on, an SCR will continue to conduct until its anode-to-cathode voltage drops to zero, so the SCR continues to conduct until the end of the half-cycle.

Figure 4-2 Conduction of one SCR when turned on at the beginning of a half-cycle

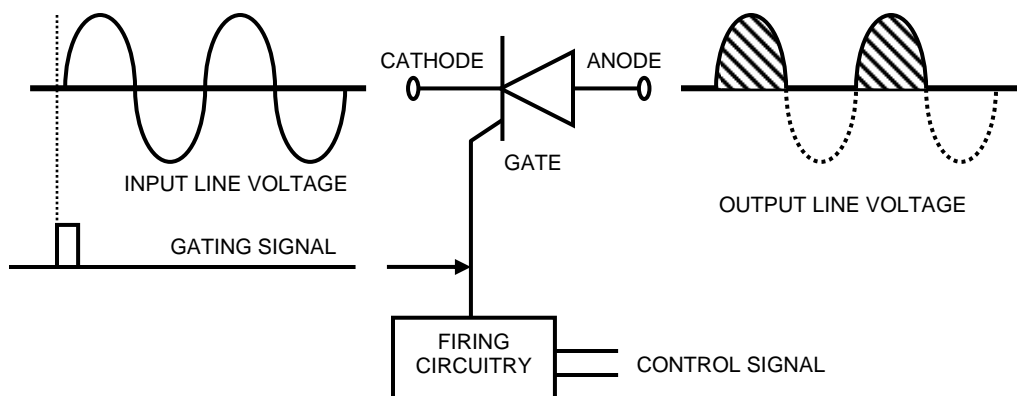

Because an SCR is a type of diode, it can conduct only during every other half-cycle of the applied voltage. Therefore, SCRs used to control AC power are usually installed in pairs, connected in reverse-parallel, as shown in figure 4-3. One of the SCRs then can be fired during the positive half-cycle and the other can be fired during the negative half-cycle.

Figure 4-3 Conduction of two SCRs connected in reverse parallel when turned on at the beginning of half-cycles

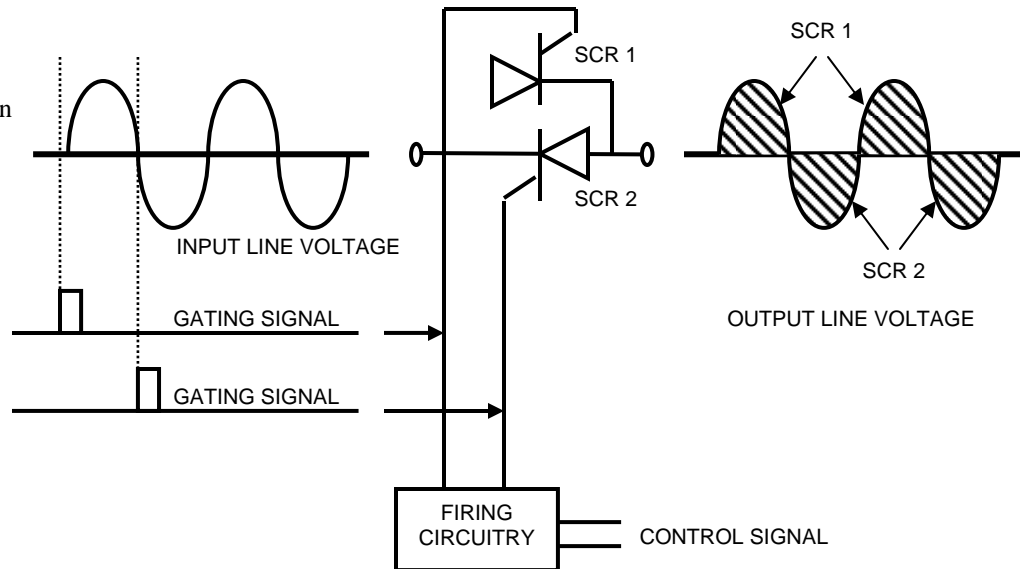

Principles of Phase Angle Control

In phase angle controllers, the SCRs conduct during all or part of every half-cycle. When delivering full power, the SCRs start conducting at the beginnings of the AC half-cycles. When delivering less than maximum power, the gating signal is de-layed so the SCRs start conducting some time later than the beginnings of the half-cycles. Operation of a phase angle controller at partial output is depicted in figure 4-4.

Figure 4-4 Conduction of two SCRs connected in reverse parallel when turned on after the beginning of the half-cycles

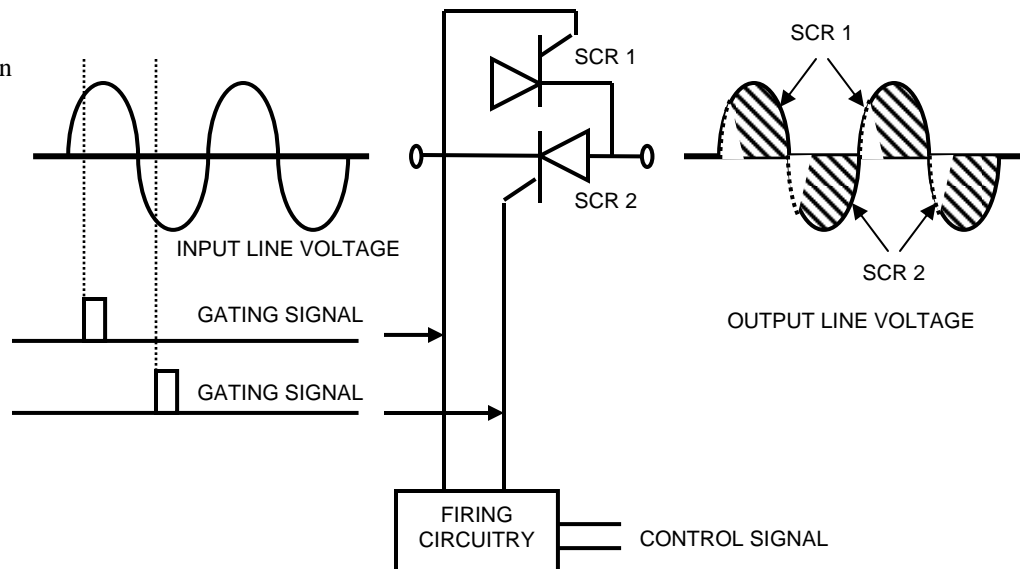

The average power a phase angle controller delivers to its load is determined by the number of electrical degrees by which the gating signal that turns on the SCRs is delayed past the beginnings of the half-cycles. The later in each half-cycle the SCRs fire, the less the time the SCRs conduct during each half-cycle and, therefore, the less power is delivered to the load (see figure 4-5). The 0–5 VDC control signal received by the phase angle firing-circuit determines the amount by which the gating signal is delayed.

Figure 4-5 Phase angle power control

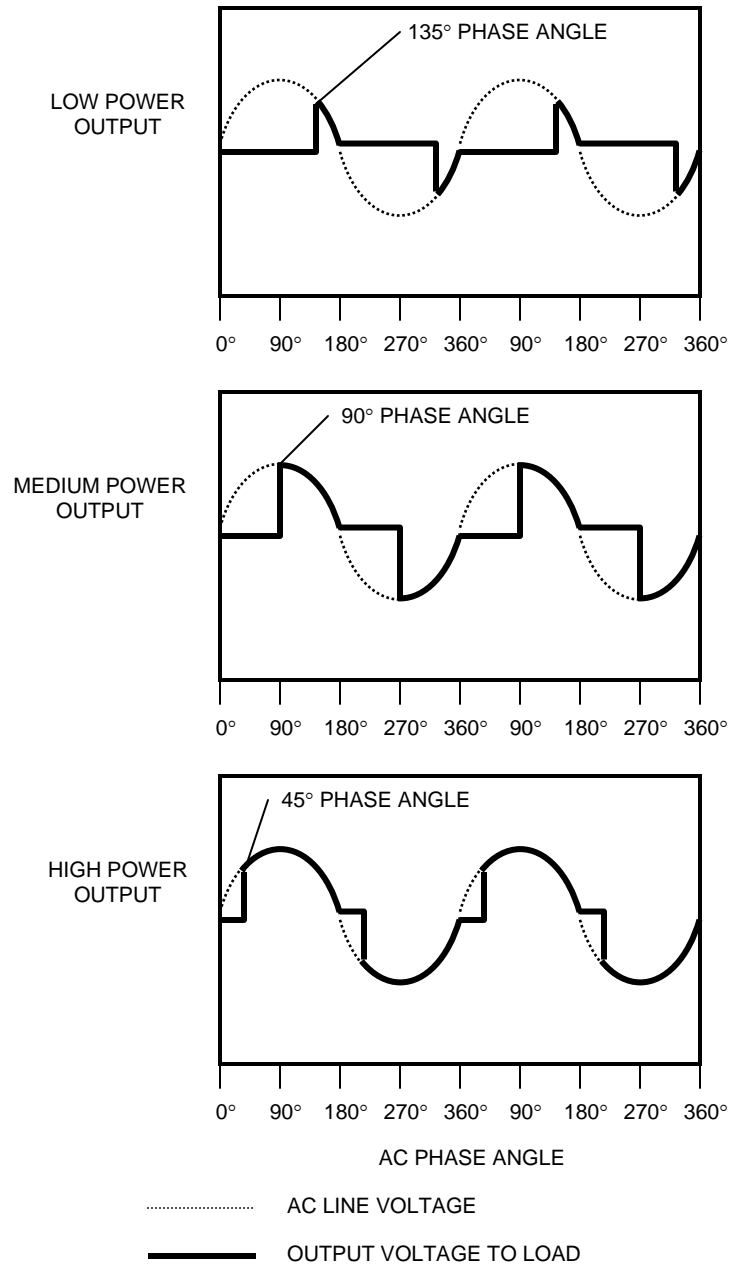

The output voltage of a phase angle controller does not change linearly with respect to the number of degrees the SCR conduction phase angle changes. Therefore, the SCR controllers have a built-in load feedback circuit to linearize the relationship between the control signal and the voltage output. The feedback circuit also adjusts the power controller output to compensate for changes in line voltage and load impedance (this is called "line and load regulation").

Phase angle power control offers a number of attractive features. Because the power controller output level is adjusted by varying the SCR on time within each AC half-cycle, the controller's output is quite constant, rather than being divided into multiple-cycle periods of on time and off time. In addition, a variety of feedback and output indication (metering) circuits can easily be incorporated into the controller.

Maintenance and Trouble Shooting

ROUTINE MAINTENANCE

The following bi-monthly routine maintenance is suggested:

1. Remove power connection to the system. Lock out power if possible. Carefully vacuum any dust or dirt collecting within the enclosure. Use caution to not disturb the wiring. Service more often in dust locations.
2. Clean the outside of the enclosure with glass cleaner and a soft cotton cloth as necessary.

TROUBLESHOOTING

Symptom	Action
Heater Contactor will not energize.	<ol style="list-style-type: none"> 1. Verify line voltage is applied to the main disconnect switch. 2. Verify remote heater open, remote process interlocks or water flow switches (if used) are closed. 3. If not using remote heater enable, heater open interlocks or water flow switches, verify the 2 pin jumpers are installed between TB 100 pins 2 to 3, 10 to 11 and 14 to 15. 4. Check fuses FU 1050, FU 1051, FU 107, FU 108 and TB 100 pin 1.
No output to load, heaters or lamps. Setpoint switch is in LOCAL mode.	<ol style="list-style-type: none"> 1. Verify the 'Heater On' indicator is illuminated. 2. Verify a 0-5 VDC signal is present on pins 13 and 14 of the power controller connector. This voltage is proportional to the setting of the local Setpoint potentiometer or the idle potentiometer (product detect option) if product is not detected. 3. If the over current light on the controller is illuminated, check the load wiring, lamp or heater connections for short circuits. 4. If the shorted SCR light is lit on the controller, refer to the power controller manual regarding repairs. 5. If the COMMAND led on the power controller is not lit and a control signal is greater than 10 percent is applied, refer to the power controller manual regarding repairs.

Symptom	Action
No output to load, heaters or lamps. Setpoint switch is in REMOTE. Operation O.K. with Setpoint switch in LOCAL (if not see above).	<ol style="list-style-type: none"> 1. Verify the polarity of the remote input. TB 100 pin 16 is positive, and 17 is negative. 2. Units with Temperature control option: Place temperature controller in manual mode with 50 percent output. Verify 2.5VDC at TB 100 pins 16 and 17. Refer to the temperature controller manual regarding repairs.
Full voltage cannot be obtained.	<ol style="list-style-type: none"> 1. Verify the load, lamps, or heaters are not drawing current at full capacity of the system. Rotate the current limit pot on the power controller 1 turn counterclockwise. If the load current decreases, the current limit is controlling the output. 2. Verify the line voltage. Load voltage maximum is approximately 98 percent of the line voltage. 3. Test in LOCAL setpoint mode. Set the 'Local Setpoint' potentiometer to 900. The voltage should be 216 (240 volt line), or 432 (480 volt line). Adjust the RUN SPAN potentiometer of the power controller as necessary. 4. Faulty power controller SCR or control circuit. Refer to the power controller manual regarding repairs.
Load voltage will not go to zero.	<ol style="list-style-type: none"> 1. Verify the load voltage will go to zero with the SCR switch set to DISABLED. If it does not, refer to the power controller manual regarding repairs. 2. If the shorted SCR indicator of the power controller is on, an SCR has failed. 3. Units with the Product Detect option: Normal operation of the idle circuit. The idle potentiometer maintains the voltage at idle. 4. Units with the Conveyor / Web speed option: Normal operation. The minimum idle potentiometer may be adjusted to lower the load voltage to zero if the web is stopped.

CALIBRATION

Generally components of the power control system hold their calibration very well over a long period of time. Usually verification of calibration is all that is necessary. We suggest verification or calibration be performed on a yearly basis. Calibration should be performed by qualified personnel as dangerous voltages are present.

Power Controller

Refer to the power controller manual for specific calibration instructions. Calibrate using step 1, 2 or 3 below (use whichever is used most often):

1. When LOCAL setpoint mode is selected, the local setpoint potentiometer is used as the source for the input. Adjust the zero and span potentiometers on the power controller. The SPAN potentiometer is adjusted for 90 percent or rated line voltage for 900 dial divisions of the local setpoint pot. The ZERO potentiometer is adjusted for 0 Volts output when the local setpoint is set to 000 dial divisions.

2. Voltmeter Option or No Options: When REMOTE setpoint mode is selected, use a 0-5 VDC source for an input. Adjust the zero and span potentiometers on the power controller. The SPAN potentiometer is adjusted for 90 percent of rated line voltage for 4.5 VDC input. The ZERO potentiometer is adjusted for 0 Volts output when the local setpoint is set to 000 dial divisions.
3. Temperature Controller option only: When AUTO setpoint mode is selected, the temperature controller is used as the source for the input. Adjust the zero and span potentiometers on the power controller. The SPAN potentiometer is adjusted for 90 percent of rated line voltage for 90 percent output of the temperature controller. The ZERO potentiometer is adjusted for 0 volts output when the temperature controller is set to 0 percent.

Panel Voltmeter Calibration

The front panel load voltmeter is calibrated to match as closely as possible the true RMS voltage measured at the load terminals.

1. Connect a true RMS DVM to load 1 and load 2.
2. Connect another DVM across pins 1(+) and 2(-) of the EXT 200 RMS voltage transmitter.
3. Turn the HEATER switch to OFF. Measure the voltage of EXT 200 pins 1(+) and 2(-) to be 0.0 VDC +/- 10 millivolts. Adjust the EXT 200 zero potentiometer if necessary.
4. Verify the panel voltmeter reads 0 volts. If necessary, carefully remove the front cover of the meter and adjust the zero potentiometer for 000 +/- 1 reading.
5. Turn the Heater switch to ON. Adjust the LOCAL SETPOINT potentiometer for the following load voltage based on the voltage your system is configured for:
 480 VAC units: 450 VAC
 240 VAC units: 225 VAC
6. Measure the voltage of EXT 200 pins 1(+) and 2(-) to be the following voltage +/- 10 millivolts:
 480 VAC units: 3.750 VDC
 240 VAC units: 1.875 VDC
7. Verify that the panel voltmeter reads the voltage as set in Step 5 above. If necessary, carefully remove the front cover of the meter and adjust the span potentiometer for a +/- 1 reading.

Temperature Controller Option

Refer to the temperature controller manual for calibration instructions.

LINE VOLTAGE RE-CONFIGURATION

The AC line voltage for the Model 930 Power Control System may be re-configured. On transformer T100, a wire with wire number 1070 is connected to pins 3 or 4. Move this wire to the pin corresponding to the desired line voltage.

Pin 3	240 VAC
Pin 4	480 VAC

See Figure 5-1 below.

Figure 5-1 AC Voltage Tap

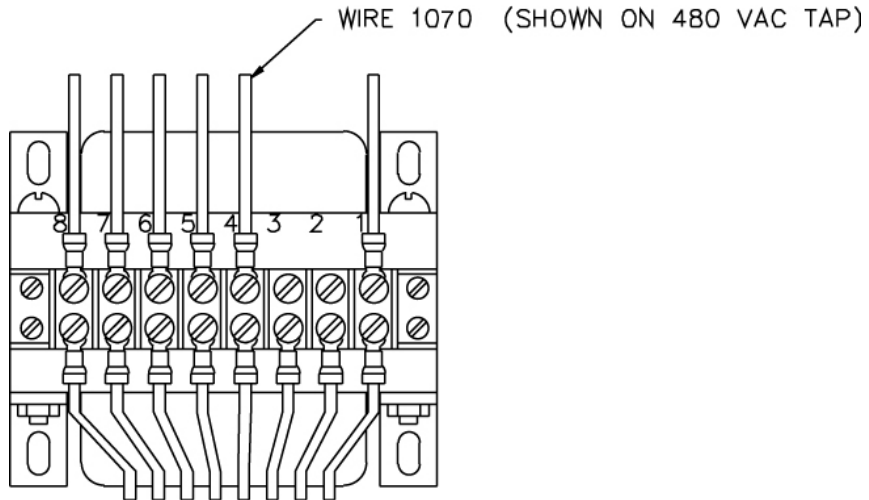

On transformer T200, it is necessary to re-configure the primary wires per the following (see Figure 5-2):

240VAC	480VAC
Jumper H1 to H3	Jumper H3 to H2
Jumper H2 to H4	

Figure 5-2 T200 Transformer

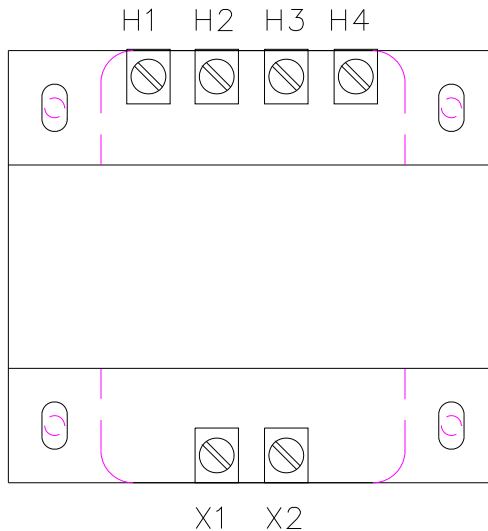

Dimensions and Specifications

SPECIFICATIONS

Environmental Limits:

Operating Temperature	0-50 deg. C (32-122 deg. F)
Storage Temperature	-40-70 deg. C (-10-158 deg. F)
Humidity	0-90 %, non-condensing
Clearance	4" (100mm) on right and left sides

Weight:

The system weight varies slightly with the options installed. The maximum weight of the system is ??? pounds (??? kg).

Operating Voltage:

240 or 480-VAC +10%, -15% at 50 or 60 Hertz. Voltage set at factory per order.

Operating Current and kW:

Current Rating of System	Continuous Current Rating at 50°C	Maximum Power kW at	
		240 VAC	480 VAC
120 Amp	120 Amps	50	99.8
160 Amp	160 Amps	66.5	133

Line Fusing:

Current Rating of System	Fuse Type	Fuse Rating
120 Amp	JJS-150	Class T 150 Amp 600 Volt
160 Amp	JJS-200	Class T 200 Amp 600 Volt

Power Control:

Control Mode:

SCR phase-angle control of the voltage applied to a three phase load. True RMS voltage feedback for load voltage regulation.

Control Range:

0-98% of supply voltage.

Output Linearity:

RMS load voltage varies linearly with control signal, within +/- 2 percent of span over the entire range of control.

Electrical Isolation:

Heat sink to supply and load voltage: 2500 Volts peak.
 Command signal to supply and load voltage: 1400 Volts peak.

Slew Rate:

200 ms. Slew rate is the time required for the load voltage to change 63% of the value represented by the command signal. The current limiting action will affect the slew rate if the load current is greater than the current rating of the SCRs.

Wiring Specifications

Wire Ratings:

Wire Temperature Rating:	75°C or Higher
Line/Load Wiring Voltage Rating (240 VAC systems)	300 VAC Minimum
Line/Load Wiring Voltage Rating (480 VAC systems)	600 VAC Minimum
Control Wiring	300 VAC Minimum

Allowable Wire Sizes:

Current Rating of System	Line Connections	Load Connections	Ground Connection	Control Circuit Connections
120 Amp	#6-250 MCM	#6-250 MCM	#4-1/0 AWG	22-10 AWG
160 Amp	#6-250 MCM	#6-250 MCM	#4-1/0 AWG	22-10 AWG

Recommended Minimum Wire Sizes:

NOTE:

Wire temperature and connector ampacity ratings are based on NEC table 310-16 using 75 °C copper wire derated for 50 °C ambient environment.

Current Rating of System	Line Connections	Load Connections	Ground Connection	Control Circuit Connections
120 Amp	1 AWG	6 AWG	6 AWG	16 AWG
160 Amp	2/0 AWG	4 AWG	6 AWG	16 AWG

Electrical Inputs:

Heater open interlock switch	Contacts Rated for 120 VAC at 2.0 A
Cooling flow interlock switch	Contacts rated for 120 VAC at 100 mA
Heater over-temp. thermo-switch	Contacts rated for 120 VAC at 100 mA
Remote interlock switch	Contacts rated for 120 VAC at 100 mA

Specifications for Options

Option Code		Temperature Controller Option
TCT & TCP	Thermocouple type (TCT):	Type 'K'
	Sensor Input (TCP):	4-20mA scaled 0-2500 deg. F
	Alarm relay rating:	5A @ 120VAC resistive, 3A @ 240VAC
	Sample rate:	10 HZ
	Calibration accuracy:	+/- 0.2% of full scale +/- 1 digit
	Control modes:	PID or PI, PD, P only, or On/Off
	Temperature stability:	5uV/°C max, 3uV/°C typical
	Noise Rejection:	Common Mode > 100 dB, Series Mode > 70 dB
	Autotune:	Operator initiated
Option Code		Voltmeter Option
VM	RMS Voltage transducer:	0-600 VAC to 0-5 VDC
	Overall accuracy:	+/- 2 VAC

DIMENSIONS

Figure 6-1 displays the overall dimensions of the Model 935 power control system. The dimensions include the side vents and door handle.

Figure 6-1 Model 930 Dimensions Overall

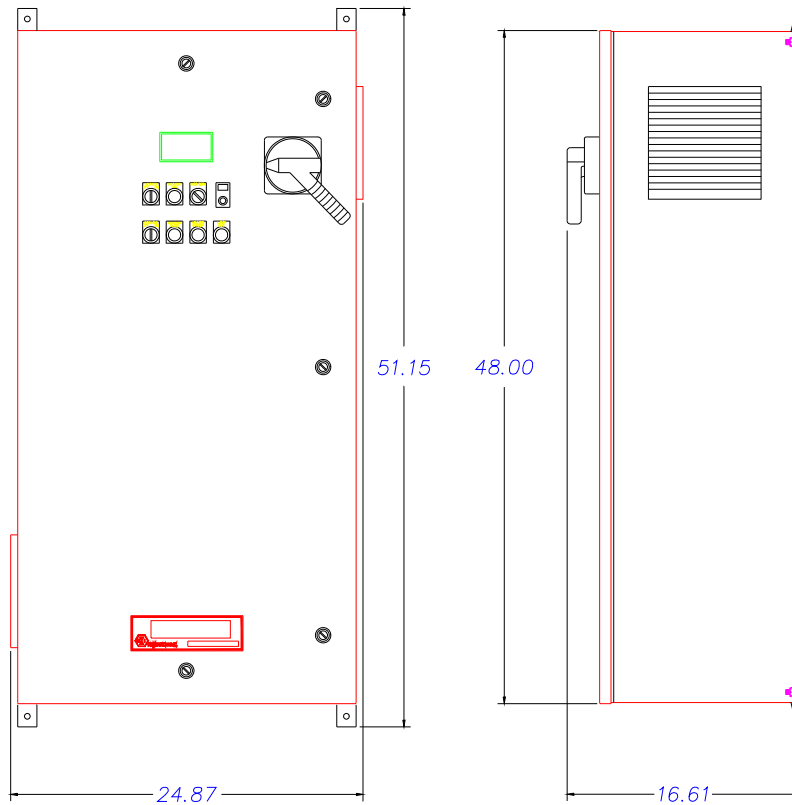
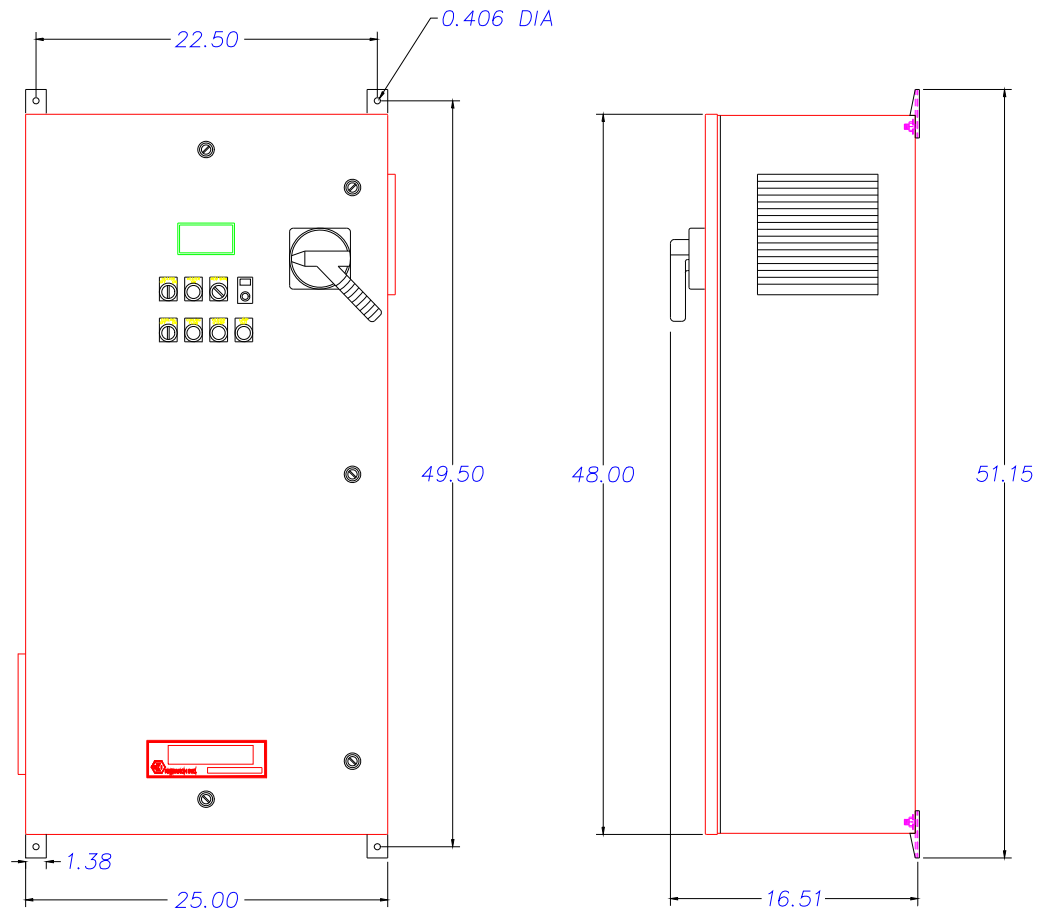

Figure 6-2 shows the mounting dimensions using the supplied brackets.

Figure 6-2 Wall Mounting Dimensions



Ordering Information

Model	Product Description
935	Three Phase SCR Power Control System
Code	Enclosure
A	Wall Mount ⁽¹⁾
Code	Line Voltage
240	240 Volts AC
480	480 Volts AC
Code	Current Capacity
120	120 Amps
160	160 Amps
Code	Options
TCP ⁽²⁾	Temperature Controller – 4/20 mA, Pyrometer Input
TCT ⁽²⁾	Temperature Controller – Thermocouple Input
VM ⁽²⁾	Digital Voltmeter
LL	Lamp-out Detection
00	None
<p>(1) Overall Dimensions (including side vents, door handle and mounting brackets): 51.15 inches High (1299.2mm) x 16.34 inches Deep (415mm).</p> <p>(2) System available with either option TCP, TCT or VM. Select one only.</p>	

Ordering Example

	Model	Enclosure	Line Voltage	Current Capacity	Options	
Typical Model Number	930	A	480	120	TCP	LL

Spare and Replacement Parts

Description	Part Number
Fuse – 200 Amp 600 VAC (For use with 160 Amp version)	089330-001
Fuse – 150 Amp 600 VAC (For use with 120 Amp version)	086160-015
Fuse – 1 Amp Time Delay "CC"	086445-015
Fuse – 2 Amp 5x20 mm Fast Act.	087146-002
True RMS AC Voltage Transmitter	097832-002
Digital Meter – 0-600 VAC	097831-005
Control Transformer – 70 VA	099366-001
Potentiometer – 1K, 10 Turn	055769-004
Digital Dial	042952-000
Switch – 2 Position Selector (contact blocks separate, see below) Remote/Local	087543-002
Switch – 3 position spring return to center (contact blocks sold separately)	087543-004
Switch – contact block 1 CON NO	087545-001
Switch – contact block 2 CON NO NC	087545-001
Pilot Light Module 120 VAC	092452-001
Model XT19 Temperature Controller (Thermocouple Input)	097399-002
Model XT19 Temperature Controller (4-20mA, Pyrometer Input)	097399-003
Main Disconnect Switch 3P 200A	105286-001
Handle for Disconnect Switch	105287-001
Contactor 3 Pole 200A	105289-001
Model 3629B Power Controller 160A	099458-043
Model 3629B Power Controller 120A	099458-041
Programmable Logic Controller 8AC in 6 Relay out with 915/935-PRJ Software	099559-001
Fuse Load 80A, 600VAC (Load Fuse 120A Version)	086797-001
Fuse Load 100A, 600VAC (Load Fuse 160A Version)	086160-010
Control Transformer 100VA 240/480-120V	075475-001